



Rotorcrafts

(Heavier-than-air flying machines)

Nakia Pressley

First Edition, 2012

ISBN 978-81-323-2802-5

© All rights reserved.

Published by:
Orange Apple
4735/22 Prakashdeep Bldg,
Ansari Road, Darya Ganj,
Delhi - 110002
Email: info@wtbooks.com

Table of Contents

Chapter 1 - Rotorcraft

Chapter 2 - Helicopter

Chapter 3 - Helicopter Rotor

Chapter 4 - Specific Types of Helicopters

Chapter 5 - Autogyro

Chapter 6 - Types of Autogyro

Chapter 7 - Gyrodyne

Chapter 8 - Specific Types of Gyrodyne

Chapter- 1

Rotorcraft



An AS332 helicopter from the Hong Kong Government Flying Service conducts a water bomb demonstration at the Hong Kong International Airport

A **rotorcraft** or **rotary wing aircraft** is a heavier-than-air flying machine that uses lift generated by wings, called rotor blades, that revolve around a mast. Several rotor blades mounted to a single mast are referred to as a rotor. The International Civil Aviation Organization (ICAO) defines a rotorcraft as "supported in flight by the reactions of the air on one or more rotors". Rotorcraft generally include those aircraft where one or more rotors are required to provide lift throughout the entire flight, such as helicopters, autogyros, and gyrodynes. Compound rotorcraft may also include additional thrust engines or propellers and static lifting surfaces.



Mil Mi-26, the world's largest production helicopter.

Rotorcraft, or rotary-wing aircraft, use a spinning rotor with aerofoil section blades (a *rotary wing*) to provide lift. Types include helicopters, autogyros and various hybrids such as gyrodynes and compound rotorcraft.

Helicopters have powered rotors. The rotor is driven (directly or indirectly) by an engine and pushes air downwards to create lift. By tilting the rotor forwards, the downwards flow is tilted backwards, producing thrust for forward flight.

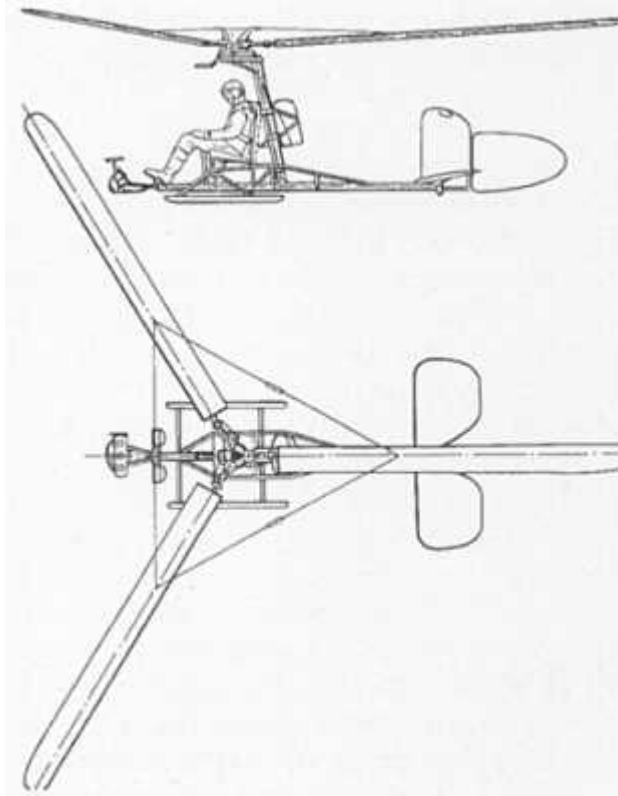

US-Recognition Manual (very likely copy of German drawing).

Autogyros or *gyroplanes* have unpowered rotors, with a separate power plant to provide thrust. The rotor is tilted backwards. As the autogyro moves forward, air blows upwards across the rotor, making it spin.(cf. Autorotation) This spinning dramatically increases the speed of airflow over the rotor, to provide lift. Juan de la Cierva (a Spanish civil engineer) used the product name *autogiro*, and Bensen used *gyrocopter*. *Rotor kites*, such as the Focke Achgelis Fa 330 are unpowered autogyros, which must be towed by a tether to give them forward ground speed or else be tether-anchored to a static anchor in a high-wind situation for kited flight.

Gyrodynes are a form of helicopter, where forward thrust is obtained from a separate propulsion device rather than from tilting the rotor. The definition of a 'gyrodyne' has changed over the years, sometimes including equivalent autogyro designs. The *Heliplane* is a similar idea.

Compound rotorcraft have wings which provide some or all of the lift in forward flight. Compound helicopters and compound autogyros have been built, and some forms of gyroplane may be referred to as compound gyroplanes. They are nowadays classified as *powered lift* types and not as rotorcraft. *Tiltrotor* aircraft (such as the V-22 Osprey) have their rotors horizontal for vertical flight, and pivot the rotors vertically like a propeller for forward flight. The *Coleopter* had a cylindrical wing forming a duct around the rotor. On the ground it sat on its tail, and took off and landed vertically like a helicopter. The whole

aircraft would then have tilted forward to fly as a propeller-driven fixed-wing aircraft using the duct as a wing (though this transition was never achieved in practice.)

Some rotorcraft have reaction-powered rotors with gas jets at the tips, but most have one or more lift rotors powered from engine-driven shafts.

Classes of rotorcraft

Helicopter

A helicopter is a rotorcraft whose rotors are driven by the engine(s) throughout the flight, to allow the helicopter to take off vertically, hover, fly forwards, backwards and laterally, as well as to land vertically. Helicopters have several different configurations of one or more main rotors.

Helicopters with one driven main rotor require some sort of antitorque device such as a tail rotor, fantail, or NOTAR, except some rare examples of helicopters using tip jet propulsion which generates almost no torque.

Autogyro



A German-registered autogyro

An autogyro (sometimes called gyrocopter, gyroplane, or rotaplane) utilizes an unpowered rotor driven by aerodynamic forces in a state of autorotation to develop lift, and an engine-powered propeller, similar to that of a fixed-wing aircraft, to provide thrust. While similar to a helicopter rotor in appearance, the autogyro's rotor must have air flowing up and through the rotor disk in order to generate rotation. Early autogyros resembled the fixed-wing aircraft of the day, with wings and a front-mounted engine and propeller in a tractor configuration to pull the aircraft through the air. Late-model autogyros feature a rear-mounted engine and propeller in a pusher configuration.

Gyrodyne



Fairey Rotodyne prototype.

The rotor of a gyrodyne is normally driven by its engine for takeoff and landing—hovering like a helicopter—with anti-torque and propulsion for forward flight provided by one or more propellers mounted on short or stub wings. As power is increased to the propeller, less power is required by the rotor to provide forward thrust resulting in reduced pitch angles and rotor blade flapping. At cruise speeds with most or all of the thrust being provided by the propellers, the rotor receives power only sufficient to the amount needed to overcome the profile drag and maintain lift. The effect is a rotorcraft operating in a more efficient manner than the freewheeling rotor of an autogyro in autorotation, and minimizing the adverse effects of retreating blade stall of helicopters at higher airspeeds.

Rotor configuration

Number of blades

A rotary wing is characterised by the number of blades. Typically this is between two and six.

Number of rotors

A rotorcraft may have one or more rotors. Various rotor configurations have been used:

- Single rotor - One rotor disc.
- Twin rotor - Two rotor discs. These usually rotate in opposite directions, so that no tail rotor or other yaw stabiliser is needed:
 - Tandem - One in front of the other.
 - Transverse - Side by side.
 - Coaxial - One rotor disc above the other, with concentric drive shafts.
- More than two rotor discs: in the case of one at each corner giving a quadrotor.

Intermeshing

Where a rotorcraft has two or more rotors, the rotor discs may be arranged to pass through each other. The blades of the two rotors must be synchronised so that they **intermesh** without touching each other.

Intermeshing rotors on a helicopter are a set of two rotors turning in opposite directions, with each rotor mast mounted on the helicopter with a slight angle to the other so that the blades intermesh without colliding. The arrangement allows the helicopter to function without the need for a tail rotor. This configuration is sometimes referred to as a **synchropter**.



Flettner Fl 282 "Kolibri" was an early ancestor of helicopters with intermeshing rotors.



HH-43 Huskie with intermeshing rotors

The arrangement was developed in Germany by Anton Flettner for a small anti-submarine warfare helicopter, the Flettner Fl 265 and later the Flettner Fl 282 Kolibri. During the Cold War the American Kaman Aircraft company produced the HH-43 Huskie, for USAF firefighting purposes. One example of the Kaman K-225 experimental synchropter was fitted with a small turboshaft engine in late 1951, becoming the world's first gas turbine powered helicopter of any type. Intermeshing rotored helicopters have high stability and powerful lifting capability. The latest Kaman K-MAX model is a dedicated sky crane design used for construction work.

Chapter- 2

Helicopter



An LAPD Bell 206

A **helicopter** is a type of rotorcraft in which lift and thrust are supplied by one or more engine driven rotors. In contrast with fixed-wing aircraft, this allows the helicopter to take off and land vertically, to hover, and to fly forwards, backwards and laterally. These attributes allow helicopters to be used in congested or isolated areas where fixed-wing aircraft would not be able to take off or land. The capability to efficiently hover for extended periods of time allows a helicopter to accomplish tasks that fixed-wing aircraft and other forms of vertical takeoff and landing aircraft cannot perform.

The word 'helicopter' is adapted from the French *hélicoptère*, coined by Gustave de Ponton d'Amecourt in 1861, which originates from the Greek *helix/helik-* (ἕλιξ) = "twisted, curved" and *pteron* (πτερόν) = "wing".

Helicopters were developed and built during the first half-century of flight, with the Focke-Wulf Fw 61 being the first operational helicopter in 1936. Some helicopters reached limited production, but it was not until 1942 that a helicopter designed by Igor Sikorsky reached full-scale production, with 131 aircraft built. Though most earlier designs used more than one main rotor, it was the single main rotor with antitorque tail rotor configuration of this design that would come to be recognized worldwide as *the helicopter*.



70PH WPB



73PH HOU.jpg



A-Great-View-of-Mt.-...



A109LUH.jpg

History

The earliest references for vertical flight have come from China. Since around 400 BC, Chinese children have played with bamboo flying toys, and the 4th-century AD Daoist book *Baopuzi* (抱朴子 "Master who Embraces Simplicity") reportedly describes some of the ideas inherent to rotary wing aircraft:

“ Someone asked the master about the principles of mounting to dangerous heights and traveling into the vast inane. The Master said, "Some have made flying cars with wood from the inner part of the jujube tree, using ox-leather [straps] fastened to returning blades so as to set the machine in motion." ”

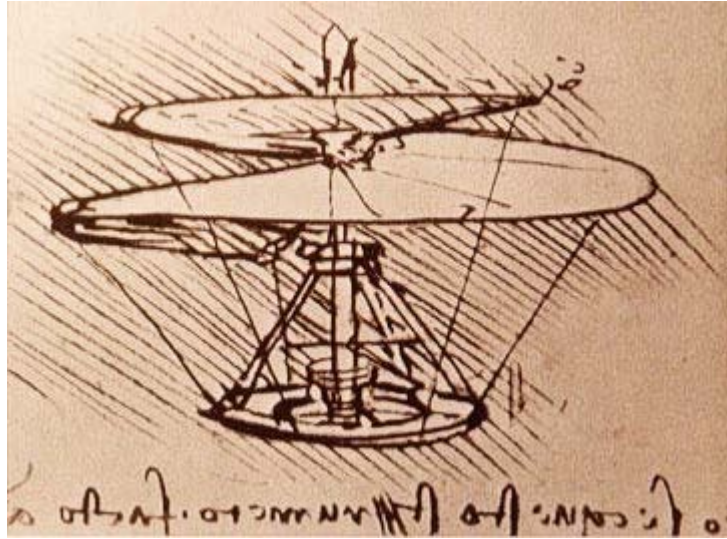

da Vinci's "aerial screw"

It was not until the early 1480s, when Leonardo da Vinci created a design for a machine that could be described as an "aerial screw", that any recorded advancement was made towards vertical flight. His notes suggested that he built small flying models, but there were no indications for any provision to stop the rotor from making the whole craft rotate. As scientific knowledge increased and became more accepted, men continued to pursue the idea of vertical flight. Many of these later models and machines would more closely resemble the ancient bamboo flying top with spinning wings, rather than Da Vinci's screw.

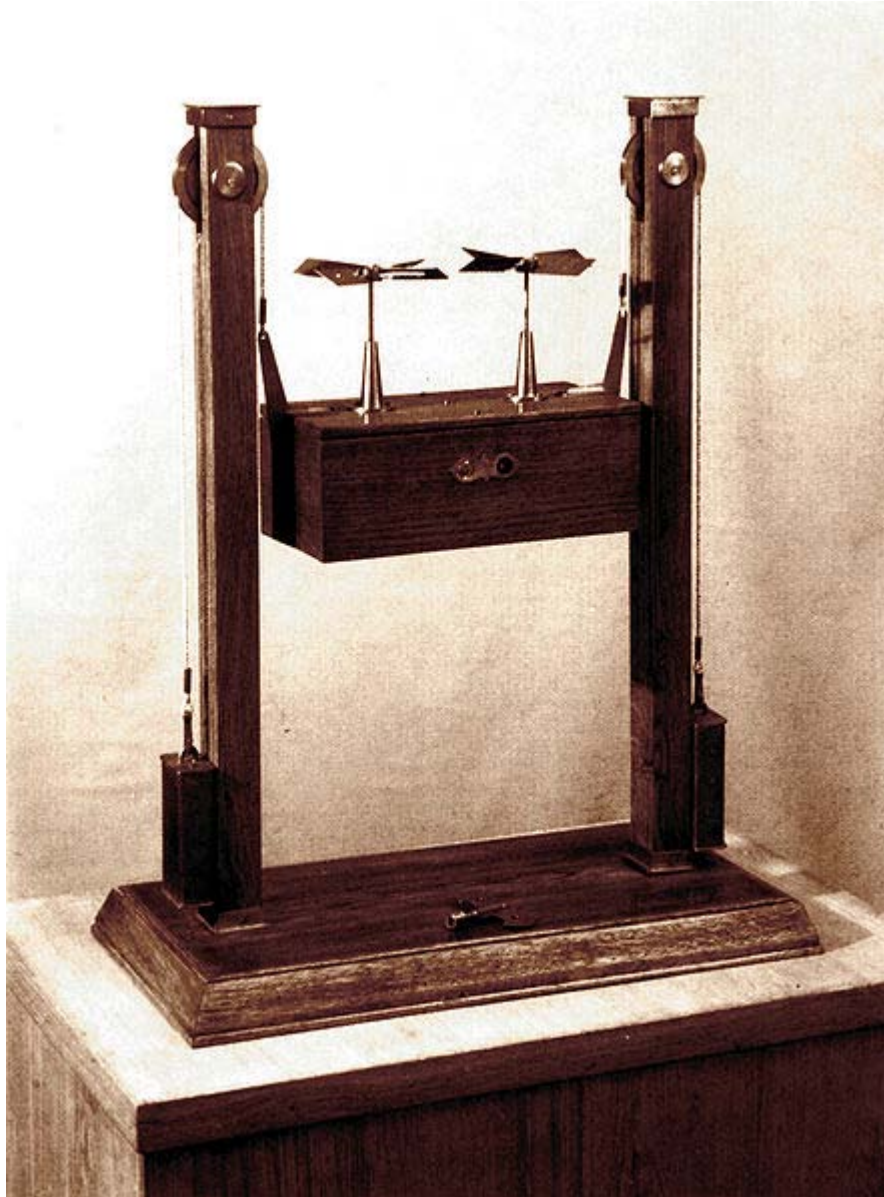

Prototype created by M. Lomonosov, 1754

In July 1754, Mikhail Lomonosov demonstrated a small coaxial rotor to the Russian Academy of Sciences. It was powered by a spring and suggested as a method to lift meteorological instruments. In 1783, Christian de Launoy, and his mechanic, Bienvenu, made a model with a pair of counter-rotating rotors, using turkey flight feathers as rotor blades, and in 1784, demonstrated it to the French Academy of Sciences. Sir George Cayley, influenced by a childhood fascination with the Chinese flying top, grew up to develop a model of feathers, similar to Launoy and Bienvenu, but powered by rubber bands. By the end of the century, he had progressed to using sheets of tin for rotor blades and springs for power. His writings on his experiments and models would become influential on future aviation pioneers. Alphonse Pénaud would later develop coaxial rotor model helicopter toys in 1870, also powered by rubber bands. One of these toys,

given as a gift by their father, would inspire the Wright brothers to pursue the dream of flight.

In 1861, the word "helicopter" was coined by Gustave de Ponton d'Amécourt, a French inventor who demonstrated a small, steam-powered model. While celebrated as an innovative use of a new metal, aluminum, the model never lifted off the ground. D'Amecourt's linguistic contribution would survive to eventually describe the vertical flight he had envisioned. Steam power was popular with other inventors as well. In 1878 Enrico Forlanini's unmanned helicopter was also powered by a steam engine. It was the first of its type that rose to a height of 12 meters (40 ft), where it hovered for some 20 seconds after a vertical take-off. Emmanuel Dieuaide's steam-powered design featured counter-rotating rotors powered through a hose from a boiler on the ground.

In 1885, Thomas Edison was given US\$1,000 by James Gordon Bennett, Jr., to conduct experiments towards developing flight. Edison built a helicopter and used the paper for a stock ticker to create gun cotton, with which he attempted to power an internal combustion engine. The helicopter was damaged by explosions and one of his workers was badly burned. Edison reported that it would take a motor with a ratio of three to four pounds per horsepower produced to be successful, based on his experiments. Ján Bahýľ, a Slovak inventor, adapted the internal combustion engine to power his helicopter model that reached a height of 0.5 meters (1.6 ft) in 1901. On 5 May 1905, his helicopter reached four meters (13 ft) in altitude and flew for over 1,500 meters (4,900 ft). In 1908, Edison patented his own design for a helicopter powered by a gasoline engine with box kites attached to a mast by cables for a rotor, but it never flew.

First flights



Paul Cornu's helicopter in 1907

In 1906, two French brothers, Jacques and Louis Breguet, began experimenting with airfoils for helicopters and in 1907, those experiments resulted in the *Gyroplane No. 1*. Although there is some uncertainty about the dates, sometime between 14 August and 29 September 1907, the Gyroplane No. 1 lifted its pilot up into the air about two feet (0.6 m) for a minute. However, the Gyroplane No. 1 proved to be extremely unsteady and required a man at each corner of the airframe to hold it steady. For this reason, the flights of the Gyroplane No. 1 are considered to be the first manned flight of a helicopter, but not a free or untethered flight.

That same year, fellow French inventor Paul Cornu designed and built a Cornu helicopter that used two 20-foot (6 m) counter-rotating rotors driven by a 24-hp (18-kW) Antoinette engine. On 13 November 1907, it lifted its inventor to 1 foot (0.3 m) and remained aloft for 20 seconds. Even though this flight did not surpass the flight of the Gyroplane No. 1, it was reported to be the first truly free flight with a pilot. Cornu's helicopter would complete a few more flights and achieve a height of nearly 6.5 feet (2 m), but it proved to be unstable and was abandoned.

The Danish inventor Jacob Ellehammer built the Ellehammer helicopter in 1912. It consisted of a frame equipped with two contra-rotating discs, each of which was fitted with six vanes around its circumference. After a number of indoor tests, the aircraft was demonstrated outdoors and made a number of free take-offs. Experiments with the helicopter continued until September 1916, when it tipped over during take-off, destroying its rotors.

Early development

In the early 1920s, Argentine Raúl Pateras Pescara, while working in Europe, demonstrated one of the first successful applications of cyclic pitch. Coaxial, contra-rotating, biplane rotors could be warped to cyclically increase and decrease the lift they produced. The rotor hub could also be tilted forward a few degrees, allowing the aircraft to move forward without a separate propeller to push or pull it. Pescara was also able to demonstrate the principle of autorotation, by which helicopters safely land after engine failure. By January 1924, Pescara's helicopter No. 3 could fly for up ten minutes.

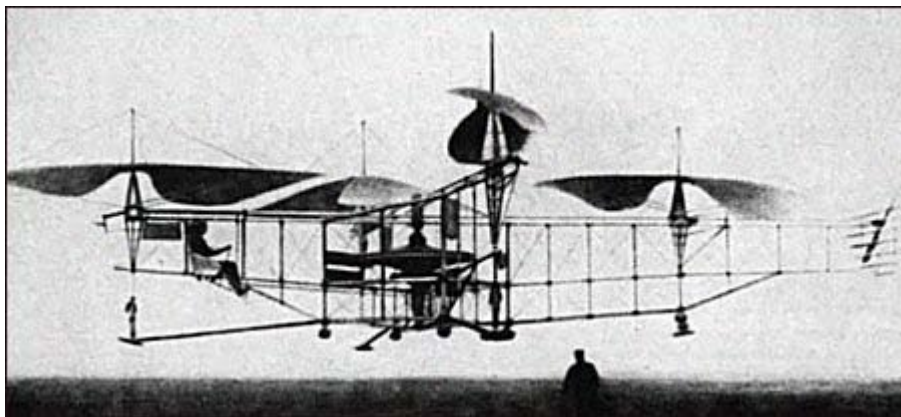

Oehmichen N°2 1922

One of Pescara's contemporaries, Frenchman Etienne Oehmichen, set the first helicopter world record recognized by the *Fédération Aéronautique Internationale* (FAI) on 14 April 1924, flying his helicopter 360 meters (1,181 ft). On 18 April 1924, Pescara beat Oemichen's record, flying for a distance of 736 meters (nearly a half mile) in 4 minutes and 11 seconds (about 8 mph, 13 km/h) maintaining a height of six feet (2 m). Not to be outdone, Oehmichen reclaimed the world record on 4 May when he flew his No. 2 machine again for a 14-minute flight covering 5,550 feet (1.05 mi, 1.69 km) while

climbing to a height of 50 feet (15 m). Oehmichen also set the 1 km closed-circuit record at 7 minutes 40 seconds.

In the USA, George de Bothezat built the quadrotor De Bothezat helicopter for the United States Army Air Service but the Army cancelled the program in 1924, and the aircraft was scrapped.

Meanwhile, Juan de la Cierva was developing the first practical rotorcraft in Spain. In 1923, the aircraft that would become the basis for the modern helicopter rotor began to take shape in the form of an autogyro, Cierva's C.4. Cierva had discovered aerodynamic and structural deficiencies in his early designs that could cause his autogyros to flip over after takeoff. The flapping hinges that Cierva designed for the C.4 allowed the rotor to develop lift equally on the left and right halves of the rotor disk. A crash in 1927, led to the development of a drag hinge to relieve further stress on the rotor from its flapping motion. These two developments allowed for a stable rotor system, not only in a hover, but in forward flight.

Albert Gillis von Baumhauer, a Dutch aeronautical engineer, began studying rotorcraft design in 1923. His first prototype "flew" ("hopped" and hovered in reality) on 24 September 1925, with Dutch Army-Air arm Captain Floris Albert van Heijst at the controls. The controls that Captain van Heijst used were Von Baumhauer's inventions, the cyclic and collective. Patents were granted to von Baumhauer for his cyclic and collective controls by the British ministry of aviation on 31 January 1927, under patent number 265,272.

In 1928, Hungarian aviation engineer Oszkár Asbóth constructed a helicopter prototype that took off and landed at least 182 times, with a maximum single flight duration of 53 minutes.

In 1930, the Italian engineer Corradino D'Ascanio built his D'AT3, a coaxial helicopter. His relatively large machine had two, two-bladed, counter-rotating rotors. Control was achieved by using auxiliary wings or servo-tabs on the trailing edges of the blades, a concept that was later adopted by other helicopter designers, including Bleeker and Kaman. Three small propellers mounted to the airframe were used for additional pitch, roll, and yaw control. The D'AT3 held modest FAI speed and altitude records for the time, including altitude (18 m or 59 ft), duration (8 minutes 45 seconds) and distance flown (1,078 m or 3,540 ft).



AH-1 on display



Aeronautica Militare...



AerospaceMuseumofCal...



Apache.JPG

In the Soviet Union, Boris N. Yuriev and Alexei M. Cheremukhin, two aeronautical engineers working at the *Tsentralniy Aerogidrodinamicheskii Institut* (TsAGI, Russian: Центральный аэрогидродинамический институт (ЦАГИ), English: *Central Aerohydrodynamic Institute*), constructed and flew the TsAGI 1-EA single rotor helicopter, which used an open tubing framework, a four blade main rotor, and twin sets of 1.8-meter (6-foot) diameter anti-torque rotors; one set of two at the nose and one set of two at the tail. Powered by two M-2 powerplants, up-rated copies of the Gnome Monosoupe rotary radial engine of World War I, the TsAGI 1-EA made several successful low altitude flights. By 14 August 1932, Cheremukhin managed to get the 1-EA up to an unofficial altitude of 605 meters (1,985 ft), shattering d'Ascanio's earlier achievement. As the Soviet Union was not yet a member of the FAI, however, Cheremukhin's record remained unrecognized.

Nicolas Florine, a Russian engineer, built the first twin tandem rotor machine to perform a free flight. It flew in Sint-Genesius-Rode, at the *Laboratoire Aérotechnique de Belgique* (now von Karman Institute) in April 1933, and attained an altitude of six meters (20 ft) and an endurance of eight minutes. Florine chose a co-rotating configuration because the gyroscopic stability of the rotors would not cancel. Therefore the rotors had to be tilted slightly in opposite directions to counter torque. Using hingeless rotors and co-rotation

also minimised the stress on the hull. At the time, it was one of the most stable helicopter in existence.

The Bréguet-Dorand *Gyroplane Laboratoire* was built in 1933. After many ground tests and an accident, it first took flight on 26 June 1935. Within a short time, the aircraft was setting records with pilot Maurice Claisse at the controls. On 14 December 1935, he set a record for closed-circuit flight with a 500-meter (1,600 ft) diameter. The next year, on 26 September 1936, Claisse set a height record of 158 meters (520 ft). And, finally, on 24 November 1936, he set a flight duration record of one hour, two minutes and 5 seconds over a 44 kilometer (27 mi) closed circuit at 44.7 kilometers per hour (27.8 mph). The aircraft was destroyed in 1943 by an Allied airstrike at Villacoublay airport.

Birth of an industry



First airmail service by helicopter in Los Angeles, 1947

Despite the success of the *Gyroplane Laboratoire*, the German Focke-Wulf Fw 61, first flown in 1936, would eclipse its accomplishments. The Fw 61 broke all of the helicopter world records in 1937, demonstrating a flight envelope that had only previously been achieved by the autogyro. Nazi Germany would use helicopters in small numbers during World War II for observation, transport, and medical evacuation. The Flettner F1 282 *Kolibri* synchropter was used in the Mediterranean, while the Focke Achgelis Fa 223 *Drache* was used in Europe. Extensive bombing by the Allied forces prevented Germany from producing any helicopters in large quantities during the war.

In the United States, Igor Sikorsky and W. Lawrence LePage were competing to produce the United States military's first helicopter. Prior to the war, LePage had received the patent rights to develop helicopters patterned after the Fw 61, and built the XR-1. Meanwhile, Sikorsky had settled on a simpler, single rotor design, the VS-300. After experimenting with configurations to counteract the torque produced by the single main rotor, he settled on a single, smaller rotor mounted vertically on the tailboom.

Developed from the VS-300, Sikorsky's R-4 became the first mass produced helicopter with a production order for 100 aircraft. The R-4 was the only Allied helicopter to see service in World War II, primarily being used for rescue in Burma, Alaska, and other areas with harsh terrain. Total production would reach 131 helicopters before the R-4 was replaced by other Sikorsky helicopters such as the R-5 and the R-6. In all, Sikorsky would produce over 400 helicopters before the end of World War II.

As LePage and Sikorsky were building their helicopters for the military, Bell Aircraft hired Arthur Young to help build a helicopter using Young's semi-rigid, teetering-blade rotor design, which used a weighted stabilizing bar. The subsequent Model 30 helicopter showed the design's simplicity and ease of use. The Model 30 was developed into the Bell 47, which became the first helicopter certificated for civilian use in the United States. Produced in several countries, the Bell 47 would stand as the most popular helicopter model for nearly 30 years.

Turbine age

In 1951, at the urging of his contacts at the Department of the Navy, Charles Kaman modified his K-225 helicopter with a new kind of engine, the turboshaft engine. This adaptation of the turbine engine provided a large amount of power to the helicopter with a lower weight penalty than piston engines, with their heavy engine blocks and auxiliary components. On 11 December 1951, the Kaman K-225 became the first turbine-powered helicopter in the world. Two years later, on 26 March 1954, a modified Navy HTK-1, another Kaman helicopter, became the first twin-turbine helicopter to fly. However, it was the Sud Aviation Alouette II that would become the first helicopter to be produced with a turbine-engine.

Reliable helicopters capable of stable hover flight were developed decades after fixed-wing aircraft. This is largely due to higher engine power density requirements than fixed-wing aircraft. Improvements in fuels and engines during the first half of the 20th century were a critical factor in helicopter development. The availability of lightweight turboshaft engines in the second half of the 20th century led to the development of larger, faster, and higher-performance helicopters. While smaller and less expensive helicopters still use piston engines, turboshaft engines are the preferred powerplant for helicopters today.

Uses

Due to the operating characteristics of the helicopter—its ability to takeoff and land vertically, and to hover for extended periods of time, as well as the aircraft's handling

properties under low airspeed conditions—it has been chosen to conduct tasks that were previously not possible with other aircraft, or were time- or work-intensive to accomplish on the ground. Today, helicopter uses include transportation, construction, firefighting, search and rescue, and military uses.



Sikorsky S-64 Skycrane lifting a prefab house



Kern County (California) Fire Department Bell 205 dropping water on fire



A British Westland WAH-64 Apache attack helicopter



HH-65 Dolphin demonstrating hoist rescue capability



A Sikorsky S-76C+ air ambulance being loaded by firefighters



RAF Westland Sea King for rescue of people in distress around the United Kingdom

A helicopter used to carry loads connected to long cables or slings is called an aerial crane. Aerial cranes are used to place heavy equipment, like radio transmission towers and large air conditioning units, on the tops of tall buildings, or when an item must be raised up in a remote area, such as a radio tower raised on the top of a hill or mountain. Helicopters are used as aerial cranes in the logging industry to lift trees out of terrain where vehicles cannot travel and where environmental concerns prohibit the building of roads. These operations are referred to as longline because of the long, single sling line used to carry the load.

Helitack is the use of helicopters to combat wildland fires. The helicopters are used for aerial firefighting (or water bombing) and may be fitted with tanks or carry helibuckets. Helibuckets, such as the Bambi bucket, are usually filled by submerging the bucket into lakes, rivers, reservoirs, or portable tanks. Tanks fitted onto helicopters are filled from a hose while the helicopter is on the ground or water is siphoned from lakes or reservoirs through a hanging snorkel as the helicopter hovers over the water source. Helitack helicopters are also used to deliver firefighters, who rappel down to inaccessible areas, and to resupply firefighters. Common firefighting helicopters include variants of the Bell 205 and the Erickson S-64 Aircrane helitanker.

Helicopters are used as air ambulances for emergency medical assistance in situations when an ambulance cannot easily or quickly reach the scene. Helicopters are also used when a patient needs to be transported between medical facilities and air transportation is the most practical method for the safety of the patient. Air ambulance helicopters are

equipped to provide medical treatment to a patient while in flight. The use of helicopters as an air ambulance is often referred to as MEDEVAC, and patients are referred to as being "airlifted", or "medevaced".

Police departments and other law enforcement agencies use helicopters to pursue suspects. Since helicopters can achieve a unique aerial view, they are often used in conjunction with police on the ground to report on suspects' locations and movements. They are often mounted with lighting and heat-sensing equipment for night pursuits.

Military forces use attack helicopters to conduct aerial attacks on ground targets. Such helicopters are mounted with missile launchers and miniguns. Transport helicopters are used to ferry troops and supplies where the lack of an airstrip would make transport via fixed-wing aircraft impossible. The use of transport helicopters to deliver troops as an attack force on an objective is referred to as Air Assault. Unmanned Aerial Systems (UAS) helicopter systems of varying sizes are being developed by companies for military reconnaissance and surveillance duties. Naval forces also use helicopters equipped with dipping sonar for anti-submarine warfare, since they can operate from small ships.

Oil companies charter helicopters to move workers and parts quickly to remote drilling sites located out to sea or in remote locations. The speed over boats makes the high operating cost of helicopters cost effective to ensure that oil platforms continue to flow. Various companies specialize in this type of operation.

Other uses of helicopters include, but are not limited to:

- Aerial photography
- Motion picture photography
- Electronic news gathering
- Reflection seismology
- Search and Rescue
- Tourism or recreation
- Transport

Design features

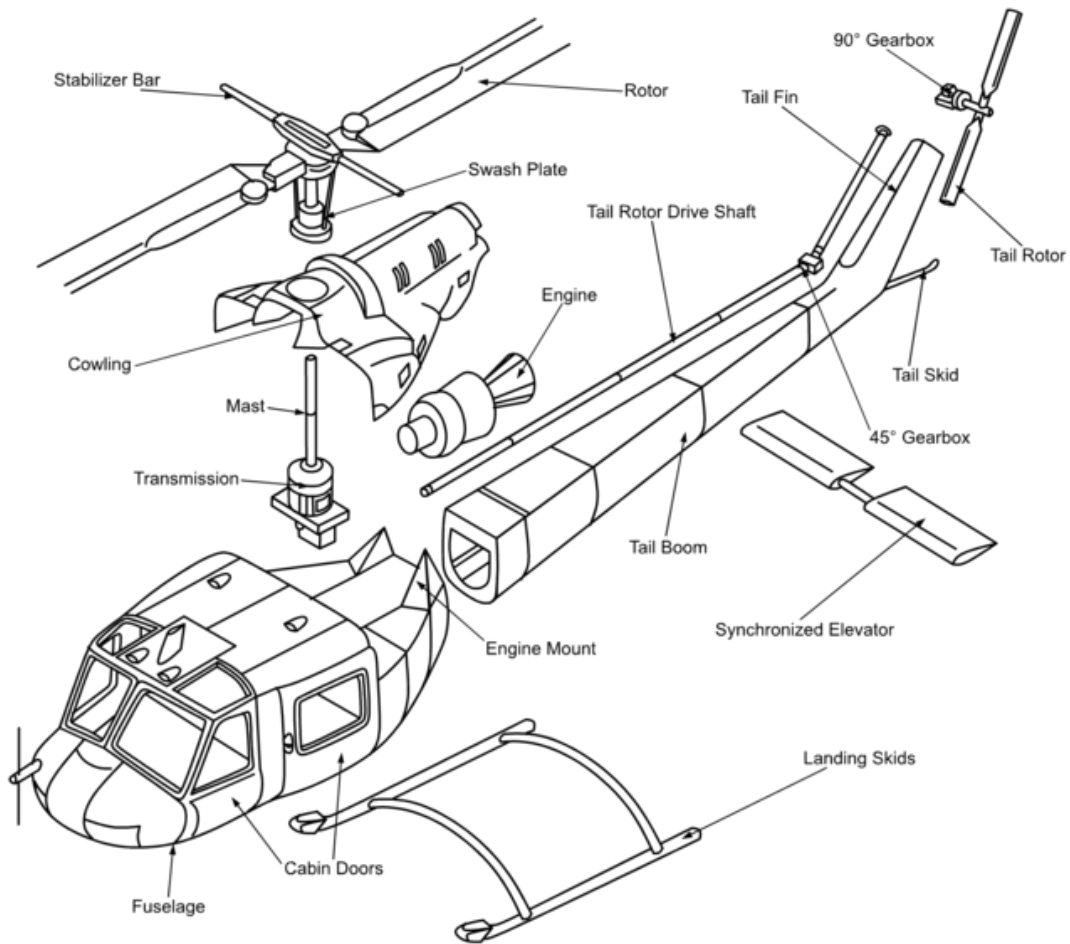

Basic anatomy of a Helicopter

Rotor system

The rotor system, or more simply *rotor*, is the rotating part of a helicopter which generates lift. A rotor system may be mounted horizontally as main rotors are, providing lift vertically, or it may be mounted vertically, such as a tail rotor, to provide lift horizontally as thrust to counteract torque effect. The rotor consists of a mast, hub and rotor blades.



A semirigid rotor system

The *mast* is a cylindrical metal shaft which extends upwards from and is driven by the transmission. At the top of the mast is the attachment point for the rotor blades called the *hub*. The rotor blades are then attached to the hub by a number of different methods. Main rotor systems are classified according to how the main rotor blades are attached and move relative to the main rotor hub. There are three basic classifications: rigid, semirigid, or fully articulated, although some modern rotor systems use an engineered combination of these types.

Antitorque configurations



MD Helicopters 520N NOTAR

Most helicopters have a single main rotor, but torque created as the engine turns the rotor against its air drag causes the body of the helicopter to turn in the opposite direction to the rotor. To eliminate this effect, some sort of antitorque control must be used. The design that Igor Sikorsky settled on for his VS-300 was a smaller rotor mounted vertically on the tail. The tail rotor pushes or pulls against the tail to counter the torque effect, and has become the recognized convention for helicopter design. Some helicopters utilize alternate antitorque controls in place of the tail rotor, such as the ducted fan (called *Fenestron* or *FANTAIL*), and NOTAR. NOTAR provides antitorque similar to the way a wing develops lift, through the use of a Coandă effect on the tailboom.

The use of two or more horizontal rotors turning in opposite directions is another configuration used to counteract the effects of torque on the aircraft without relying on an antitorque tail rotor. This allows the power normally required to drive the tail rotor to be applied to the main rotors, increasing the aircraft's lifting capacity. Primarily, there are three common configurations that use the counterrotating effect to benefit the rotorcraft. Tandem rotors are two rotors with one mounted behind the other. Coaxial rotors are two rotors that are mounted one above the other with the same axis. Intermeshing rotors are two rotors that are mounted close to each other at a sufficient angle to allow the rotors to

intermesh over the top of the aircraft. Transverse rotors is another configuration found on tiltrotors and some earlier helicopters, where the pair of rotors are mounted at each end of the wings or outrigger structures. Tip jet designs permit the rotor to push itself through the air, and avoid generating torque.

Engines

The number, size and type of engine used on a helicopter determines the size, function and capability of that helicopter design. The earliest helicopter engines were simple mechanical devices, such as rubber bands or spindles, which relegated the size of helicopters to toys and small models. For a half century before the first airplane flight, steam engines were used to forward the development of the understanding of helicopter aerodynamics, but the limited power did not allow for manned flight. The introduction of the internal combustion engine at the end of the 19th century became the watershed for helicopter development as engines began to be developed and produced that were powerful enough to allow for helicopters able to lift humans.

Early helicopter designs utilized custom-built engines or rotary engines designed for airplanes, but these were soon replaced by more powerful automobile engines and radial engines. The single, most-limiting factor of helicopter development during the first half of the 20th century was that the amount of power produced by an engine was not able to overcome the engine's weight in vertical flight. This was overcome in early successful helicopters by using the smallest engines available. When the compact, flat engine was developed, the helicopter industry found a lighter-weight powerplant easily adapted to small helicopters, although radial engines continued to be used for larger helicopters.



Aramco Helicopter.jpg



ArmyMi-17s.jpg



As355 811hs.JPG



As355cockpit krj.JPG

Turbine engines revolutionized the aviation industry, and the turboshaft engine finally gave helicopters an engine with a large amount of power and a low weight penalty. The turboshaft engine was able to be scaled to the size of the helicopter being designed, so that all but the lightest of helicopter models are powered by turbine engines today.

Special jet engines developed to drive the rotor from the rotor tips are referred to as tip jets. Tip jets powered by a remote compressor are referred to as cold tip jets, while those powered by combustion exhaust are referred to as hot tip jets. An example of a cold jet helicopter is the Sud-Ouest Djinn, and an example of the hot tip jet helicopter is the YH-32 Hornet.

Some radio-controlled helicopters and smaller, helicopter-type unmanned aerial vehicles, use electric motors. Radio-controlled helicopters may also have piston engines that use fuels other than gasoline, such as Nitromethane. Some turbine engines commonly used in helicopters can also use biodiesel instead of jet fuel.

Flight controls



Cockpit of an Alouette III

A helicopter has four flight control inputs. These are the cyclic, the collective, the anti-torque pedals, and the throttle. The cyclic control is usually located between the pilot's legs and is commonly called the *cyclic stick* or just *cyclic*. On most helicopters, the cyclic is similar to a joystick. Although, the Robinson R22 and Robinson R44 have a unique teetering bar cyclic control system and a few helicopters have a cyclic control that descends into the cockpit from overhead.

The control is called the cyclic because it changes the pitch of the rotor blades cyclically. The result is to tilt the rotor disk in a particular direction, resulting in the helicopter moving in that direction. If the pilot pushes the cyclic forward, the rotor disk tilts forward, and the rotor produces a thrust in the forward direction. If the pilot pushes the cyclic to the side, the rotor disk tilts to that side and produces thrust in that direction, causing the helicopter to hover sideways.

The collective pitch control or *collective* is located on the left side of the pilot's seat with a settable friction control to prevent inadvertent movement. The collective changes the pitch angle of all the main rotor blades collectively (i.e. all at the same time) and independently of their position. Therefore, if a collective input is made, all the blades change equally, and the result is the helicopter increasing or decreasing in altitude.

The anti-torque pedals are located in the same position as the rudder pedals in a fixed-wing aircraft, and serve a similar purpose, namely to control the direction in which the nose of the aircraft is pointed. Application of the pedal in a given direction changes the pitch of the tail rotor blades, increasing or reducing the thrust produced by the tail rotor and causing the nose to yaw in the direction of the applied pedal. The pedals mechanically change the pitch of the tail rotor altering the amount of thrust produced.

Helicopter rotors are designed to operate in a narrow range of RPM. The throttle controls the power produced by the engine, which is connected to the rotor by a fixed ratio transmission. The purpose of the throttle is to maintain enough engine power to keep the rotor RPM within allowable limits in order to keep the rotor producing enough lift for flight. In single-engine helicopters, the throttle control is a motorcycle-style twist grip mounted on the collective control, while dual-engine helicopters have a power lever for each engine.

A Swashplate transmits the pilot commands to the main rotor blades for articulated rotors.

Flight conditions

There are two basic flight conditions for a helicopter; hover and forward flight.



Helicopter hovering over boat in rescue exercise

- **Hover**
Hovering is the most challenging part of flying a helicopter. This is because a helicopter generates its own gusty air while in a hover, which acts against the fuselage and flight control surfaces. The end result is constant control inputs and corrections by the pilot to keep the helicopter where it is required to be. Despite the complexity of the task, the control inputs in a hover are simple. The cyclic is used to eliminate drift in the horizontal plane, that is to control forward and back, right and left. The collective is used to maintain altitude. The pedals are used to control nose direction or heading. It is the interaction of these controls that makes hovering so difficult, since an adjustment in any one control requires an adjustment of the other two, creating a cycle of constant correction.
- **Forward flight**
In forward flight a helicopter's flight controls behave more like that in a fixed-wing aircraft. Displacing the cyclic forward will cause the nose to pitch down, with a resultant increase in airspeed and loss of altitude. Aft cyclic will cause the nose to pitch up, slowing the helicopter and causing it to climb. Increasing collective (power) while maintaining a constant airspeed will induce a climb while decreasing collective will cause a descent. Coordinating these two inputs, down collective plus aft cyclic or up collective plus forward cyclic, will result in airspeed changes while maintaining a constant altitude. The pedals serve the same function in both a helicopter and a fixed-wing aircraft, to maintain balanced flight. This is done by applying a pedal input in whichever direction is necessary to center the ball in the turn and bank indicator.

Safety

Limitations



HAL Dhruv performing aerobatics during the Royal International Air Tattoo in 2008.



Royal Australian Navy Squirrel helicopters during a display at the 2008 Melbourne Grand Prix

The main limitation of the helicopter is its low speed. There are several reasons a helicopter cannot fly as fast as a fixed wing aircraft. When the helicopter is hovering, the outer tips of the rotor travel at a speed determined by the length of the blade and the RPM. In a moving helicopter, however, the speed of the blades relative to the air depends on the speed of the helicopter as well as on their rotational velocity. The airspeed of the advancing rotor blade is much higher than that of the helicopter itself. It is possible for this blade to exceed the speed of sound, and thus produce vastly increased drag and vibration.

Because the advancing blade has higher airspeed than the retreating blade and generates a dissymmetry of lift, rotor blades are designed to "flap" – lift and twist in such a way that the advancing blade flaps up and develops a smaller angle of attack. Conversely, the retreating blade flaps down, develops a higher angle of attack, and generates more lift. At high speeds, the force on the rotors is such that they "flap" excessively and the retreating blade can reach too high an angle and stall. For this reason, the maximum safe forward airspeed of a helicopter is given a design rating called V_{NE} , *Velocity, Never Exceed*. In addition, at extremely high speeds, it is possible for the helicopter to travel faster than the retreating blade which would inevitably stall the blade, regardless of the angle of attack.

During the closing years of the 20th century designers began working on helicopter noise reduction. Urban communities have often expressed great dislike of noisy aircraft, and police and passenger helicopters can be unpopular. The redesigns followed the closure of

some city heliports and government action to constrain flight paths in national parks and other places of natural beauty.

Helicopters also vibrate; an unadjusted helicopter can easily vibrate so much that it will shake itself apart. To reduce vibration, all helicopters have rotor adjustments for height and weight. Blade height is adjusted by changing the pitch of the blade. Weight is adjusted by adding or removing weights on the rotor head and/or at the blade end caps. Most also have vibration dampers for height and pitch. Some also use mechanical feedback systems to sense and counter vibration. Usually the feedback system uses a mass as a "stable reference" and a linkage from the mass operates a flap to adjust the rotor's angle of attack to counter the vibration. Adjustment is difficult in part because measurement of the vibration is hard, usually requiring sophisticated accelerometers mounted throughout the airframe and gearboxes. The most common blade vibration adjustment measurement system is to use a stroboscopic flash lamp, and observe painted markings or coloured reflectors on the underside of the rotor blades. The traditional low-tech system is to mount coloured chalk on the rotor tips, and see how they mark a linen sheet. Gearbox vibration most often requires a gearbox overhaul or replacement. Gearbox or drive train vibrations can be extremely harmful to a pilot. The most severe being pain, numbness, loss of tactile discrimination and dexterity.

Hazards

As with any moving vehicle, unsafe operation could result in loss of control, structural damage, or fatality. The following is a list of some of the potential hazards for helicopters:

- Settling with power, also known as a vortex ring state, is when the aircraft is unable to arrest its descent due to the rotor's downwash interfering with the aerodynamics of the rotor.
- Retreating blade stall is experienced during high speed flight and is the most common limiting factor of a helicopter's forward speed.
- Ground resonance affects helicopters with fully articulated rotor systems having a natural lead-lag frequency less than the blade rotation frequency.
- Low-G condition affects helicopters with two-bladed main rotors, particularly lightweight helicopters.
- Dynamic rollover in which the helicopter pivots around one of the skids and 'pulls' itself onto its side.
- Powertrain failures, especially those that occur within the shaded area of the height-velocity diagram.
- Tail rotor failures which occur from either a mechanical malfunction of the tail rotor control system or a loss of tail rotor thrust authority, called Loss of Tail-rotor Effectiveness (LTE).
- Brownout in dusty conditions or whiteout in snowy conditions.
- Low Rotor RPM, or *rotor droop*, in which the engine cannot drive the blades at sufficient RPM to maintain flight.

- Rotor Overspeed, which can over-stress the rotor hub pitch bearings (Brinelling) and, if severe enough, cause blade separation from the aircraft.
- Wire and tree strikes due to low altitude operations and take-offs and landings in remote locations.
- Controlled flight into terrain in which the aircraft is flown into the ground unintentionally due to lack of situational awareness.

Deadliest crashes

1. 2002: A Mil Mi-26 was shot down over Chechnya; 127 killed.
2. 1997: An Israeli CH-53 crashed in Israel; 73 killed.
3. December 14, 1992: Georgian forces in Abkhazia shot down a Russian Army Mi-8 by SA-14 MANPADs with the loss of three crew members and 58 passengers, mainly Russian refugees.
4. October 4, 1993: A Georgian Mi-8 was shot down while transporting 60 refugees from eastern Abkhazia.
5. May 10, 1977: An Israeli CH-53 crashed near Yitav in the Jordan Valley; 54 killed.
6. September 11, 1982: A U.S. Army CH-47 Chinook crashed at an air show in Mannheim, Germany; 46 killed.
7. 1986: A British International Helicopters Boeing 234LR Chinook crashed in the Shetland Islands; 45 killed.
8. 1992 Azerbaijani Mil Mi-8 shootdown: 44 killed.
9. 2009 Pakistan Army Mil Mi-17 crash: 41 killed.
10. January 26, 2005: An USMC CH-53E crashed near Ar Rutbah, Iraq killing all 31 service members onboard.

World records

Record type	Record	Helicopter	Pilot(s)	Date	Location	Note
Speed	400.87 km/h	Westland Lynx	John Trevor Egginton	11 August 1986	England	
Distance without landing	3,561.55 km	Hughes YOHO-6A	Robert G. Ferry (USA)	6 April 1966	USA	
Around-the-world speed	136.7 km/h	Agusta A109S Grand	Scott Kasprovicz (USA)	August 2008	From and to New York via Europe, Russia, Alaska, Canada	No in-flight refueling

Highest level flight altitude	11,010 m	Sikorsky CH-54 Tarhe	James K. Church	4 Nov 1971	USA
Altitude with 40-tonne payload	2,255 m	Mil V-12	Vasily Kolochenko et al	6 Aug 1969	Soviet Union

Chapter- 3

Helicopter Rotor



The rotor head of a Sikorsky S-92

A **helicopter main rotor** or **rotor system** is a type of fan that is used to generate both the aerodynamic lift force that supports the weight of the helicopter, and thrust which counteracts aerodynamic drag in forward flight. Each main rotor is mounted on a vertical mast over the top of the helicopter, as opposed to a helicopter tail rotor, which is connected through a combination a drive shaft(s) and gearboxes along the tail boom. A helicopter's rotor is generally made up of two or more rotor blades. The blade pitch is typically controlled by a swashplate connected to the helicopter flight controls.

Helicopter rotor diameters are relatively large, as this gives much better energy and propellant efficiency for the speeds at which helicopters fly.

History and development



Bundesarchiv, Bild 102-12440
Foto: o. Ang. | Oktober 1931

Helicopter rotor of Engelbert Zaschka, German master engineer, 1931, image from the German Federal Archives

Before the development of powered helicopters in the mid 20th century, autogyro pioneer Juan de la Cierva researched and developed many of the fundamentals of the rotor. Cierva is credited with successful development of multi-bladed, fully articulated rotor systems. This type of system is widely used today in many multi-bladed helicopters.

In the 1930s, Arthur Young improved the stability of two-bladed rotor systems with the introduction of a stabilizer bar. This system was used in several Bell and Hiller helicopter models. It is also used in many remote control model helicopters.

Design

A helicopter rotor is powered by the engine, through the transmission, to the rotating mast. The mast is a cylindrical metal shaft which extends upward from—and is driven by—the transmission. At the top of the mast is the attachment point for the rotor blades called the hub. The rotor blades are then attached to the hub. Main rotor systems are classified according to how the main rotor blades are attached and move relative to the main rotor hub. There are three basic classifications: rigid, semirigid, or fully articulated,

although some modern rotor systems use an engineered combination of these classifications.

Unlike the small diameter fans used in turbofan jet engines, the main rotor on a helicopter has a quite large diameter, permitting a large quantity of air to be accelerated. This permits a lower downwash velocity for a given amount of thrust. As it is more efficient at low speeds to accelerate a large amount of air by a small degree than a small amount of air by a large degree it greatly increases the aircraft's energy efficiency and this reduces the fuel use and permits reasonable range.

Parts and functions



The simple rotor of a Robinson R22



Robinson R44 rotor head

The simple rotor of a Robinson R22 showing (from the top):

- The following are driven by the link rods from the rotating part of the swashplate.
 - Pitch hinges, allowing the blades to twist about the axis extending from blade root to blade tip.
- Teeter hinge, allowing one blade to rise vertically while the other falls vertically. This motion occurs whenever translational relative wind is present, or in response to a cyclic control input.
- Scissor link and counterweight, carries the main shaft rotation down to the upper swashplate
- Rubber covers protect moving and stationary shafts
- Swashplates, transmitting cyclic and collective pitch to the blades (the top one rotates)
- Three non-rotating control rods transmit pitch information to the lower swashplate
- Main mast leading down to main gearbox

Swash plate

The pitch of main rotor blades can be varied cyclically throughout its rotation in order to control the direction of rotor thrust vector (the part of the rotor disc where the maximum thrust will be developed, front, rear, right side, etc.). Collective pitch is used to vary the magnitude of rotor thrust (increasing or decreasing thrust over the whole rotor disc at the

same time). These blade pitch variations are controlled by tilting and/or raising or lowering the swash plate with the flight controls. The vast majority of helicopters maintain a constant rotor speed (RPM) during flight, leaving only the angle of attack of the blades as the sole means of adjusting thrust from the rotor.

The swash plate is two concentric disks or plates, one plate rotates with the mast, connected by idle links, while the other does not rotate. The rotating plate is also connected to the individual blades through pitch links and pitch horns. The non-rotating plate is connected to links which are manipulated by pilot controls, specifically, the collective and cyclic controls.

The swash plate can shift vertically and tilt. Through shifting and tilting, the non-rotating plate controls the rotating plate, which in turn controls the individual blade pitch.

Fully articulated

Juan de la Cierva developed the fully articulating rotor for the autogyro, and it is the basis of his design that permitted successful helicopter development. In a fully articulated rotor system, each rotor blade is attached to the rotor hub through a series of hinges which allow the blade to move independently of the others. These rotor systems usually have three or more blades. The blades are allowed to flap, feather, and lead or lag independently of each other. The horizontal hinge, called the flapping hinge, allows the blade to move up and down. This movement is called flapping and is designed to compensate for dissymmetry of lift. The flapping hinge may be located at varying distances from the rotor hub, and there may be more than one hinge. The vertical hinge, called the lead-lag or drag hinge, allows the blade to move back and forth. This movement is called lead-lag, dragging, or hunting. Dampers are usually used to prevent excess back and forth movement around the drag hinge. The purpose of the drag hinge and dampers is to compensate for the acceleration and deceleration caused by momentum conservation, and not by Coriolis Effect. Each blade can also be feathered, that is, rotated around its spanwise axis. Feathering the blade means changing the pitch angle of the blade. By changing the pitch angle of the blades the thrust and direction of the main rotor disc can be controlled. An example of this type of rotor system is the Agusta AW109 series of aircraft; later models have switched from a traditional bearing system to an Elastomeric bearing based system.

Rigid

The term "rigid rotor" usually refers to a hingeless rotor system with blades flexibly attached to the hub. The two basic types of rigid rotor include the Reiseler-Kreiser feathering system and the Lockheed flapping system. The Reiseler-Kreiser feathering rigid rotor was developed and tested on a series of gyroplanes sponsored by E.B. Wilford in Pennsylvania. Irven Culver of Lockheed developed one of the first flapping rigid rotors and was tested and developed on a series of helicopters in the 1960s and 1970s. In a flapping rigid rotor system, each blade flaps, drags, and feathers (depending on the design) about flexible sections of the root. The flapping rigid rotor system is

mechanically simpler than the fully articulated rotor system. Loads from flapping and lead/lag forces are accommodated by bending rather than through hinges. By flexing, the blades themselves compensate for the forces which previously required rugged hinges. The result is a rotor system that has less lag in the control response, because the rotor has much less oscillation. The rigid rotor system also negates the danger of mast bumping inherent in semi-rigid rotors. The rigid rotor can also be called a hingeless rotor. Developed most notably for the XH-51 high speed and AH-56 Cheyenne attack compound helicopter, the rotors simplified aerobatic maneuvers at high speeds, but proved troublesome to perfect on the AH-56, and would never be produced in large numbers or adopted by other helicopter makers.

However, to completely contradict the previous statement, flapping rigid rotors have long been standard equipment on the Bolkow series of helicopters, as well as models produced by Aerospatiale, AgustaWestland, and MD helicopters.

Semirigid



Semirigid rotor system

The semirigid rotor can also be referred to as a teetering or seesaw rotor. This system is normally composed of two blades which meet just under a common flapping, or teetering hinge at the rotor shaft. This allows the blades to flap together in opposite motions like a

seesaw. This underslinging of the blades below the teetering hinge, combined with an adequate dihedral or coning angle on the blades, minimizes variations in the radius of each blade's center of mass from the axis of rotation as the rotor turns, which in turn reduces the stress on the blades from lead and lag forces caused by coriolis effect. Secondary flapping hinges may also be provided to provide sufficient flexibility to minimize bouncing. Feathering is accomplished by the feathering hinge at the blade root, which allows changes to the pitch angle of the blade. The most widespread implementations of this system are the Bell 206/OH-58 series of aircraft and the Robinson R22 series.

Stabilizer bar

A number of engineers, among them Arthur M. Young in the U.S., and Dieter Schlüter in Germany, found that flight stability for helicopters could be achieved with a stabilizer bar or flybar. The stabilizer bar has weighted ends which cause the bar to stay relatively stable in the plane of rotation. Through mechanical linkages, the stable rotation of the bar is mixed with the swashplate movement so that internal (steering) as well as external (wind) forces on the rotor are dampened. This eases the workload of the pilot to maintain control of the aircraft. Stanley Hiller arrived at a similar method to improve stability by adding short stubby airfoils, or paddles, at each end; However, Hiller's "Rotomatic" system was also used to deliver cyclic control inputs to the main rotor as a sort of control rotor, the paddles provided the added stability by dampening the effects of external forces on the rotor.

In fly-by-wire helicopters or RC models, a microcontroller with gyroscopes and a venturi sensor can replace the stabilizer. This *flybar-less* design has the advantage of easy reconfiguration and fewer mechanical parts.

Combination

Modern rotor systems may use the combined principles of the rotor systems mentioned above. Some rotor hubs incorporate a flexible hub, which allows for blade bending (flexing) without the need for bearings or hinges. These systems, called "flextures", are usually constructed from composite material. Elastomeric bearings may also be used in place of conventional roller bearings. Elastomeric bearings are bearings constructed from a rubber type material and have limited movement that is perfectly suited for helicopter applications. Flextures and elastomeric bearings require no lubrication and, therefore, require less maintenance. They also absorb vibration, which means less fatigue and longer service life for the helicopter components. Examples include Bell 407, Bell 430, Eurocopter A-Star(AS350)/Twin-Star(AS355) and arguably MD Helicopters (Formerly Hughes 500), this model has externally mounted lead-lag dampeners {which makes it more of a hingeless fully articulated hub}.

Rotor configurations

Most helicopters have a single, main rotor but require a separate rotor to overcome torque. This is accomplished through a variable pitch, antitorque rotor or tail rotor. This is the design that Igor Sikorsky settled on for his VS-300 helicopter and it has become the recognized convention for helicopter design, although designs do vary. When viewed from above, the main rotors of helicopter designs from Germany, United Kingdom and the United States rotate counter-clockwise, all others rotate clockwise. This can make it difficult when discussing aerodynamic effects on the main rotor between different designs, since the effects may manifest on opposite sides of each aircraft.

Single main rotor

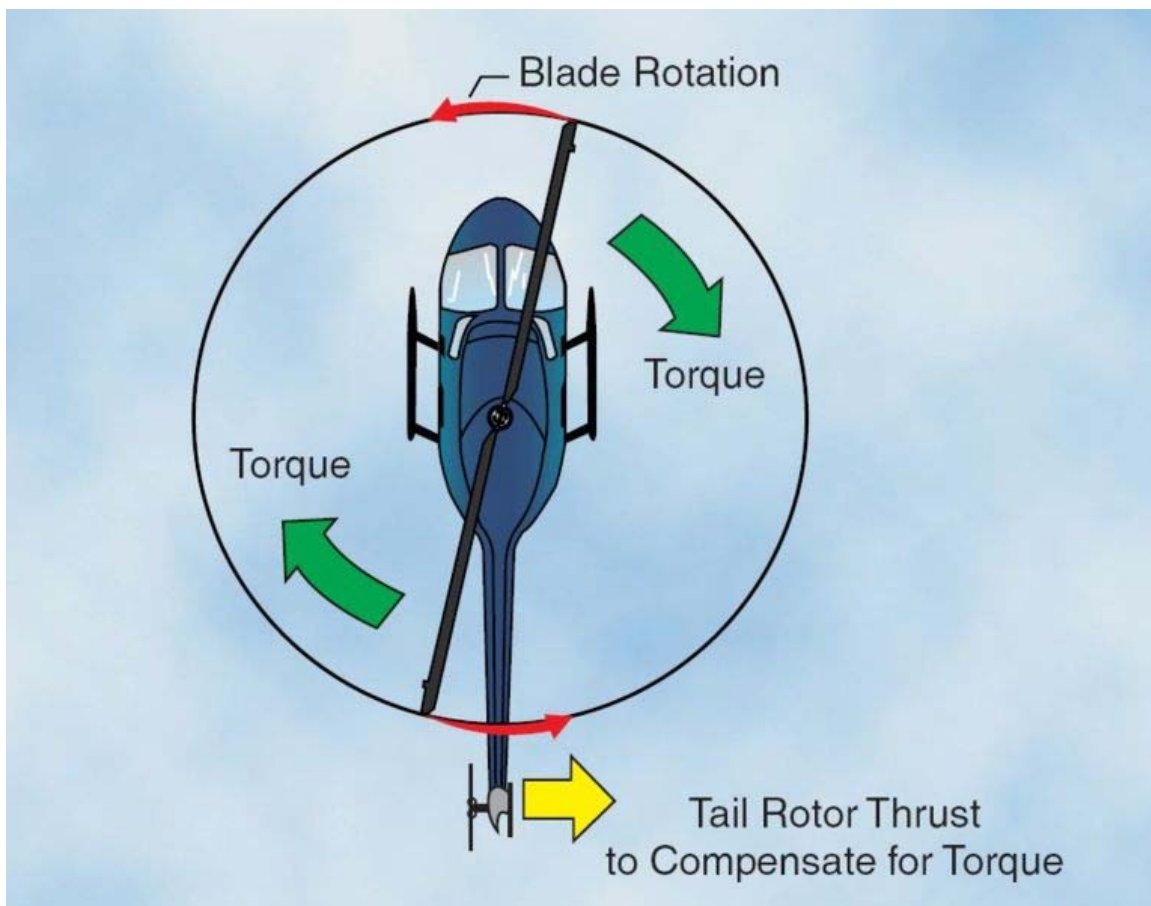

Antitorque: Torque effect on a helicopter

With a single main rotor helicopter, the creation of torque as the engine turns the rotor creates a torque effect that causes the body of the helicopter to turn in the opposite direction of the rotor. To eliminate this effect, some sort of antitorque control must be used, with a sufficient margin of power available to allow the helicopter to maintain its heading and provide yaw control. The three most common controls used today are the

traditional *tail rotor*, Eurocopter's *Fenestron* (also called a *fantail*), and MD Helicopters' *NOTAR*.

Tail rotor



Tail rotor of an SA 330 Puma

The tail rotor is a smaller rotor mounted so that it rotates vertically or near-vertically at the end of the tail of a traditional single-rotor helicopter. The tail rotor's position and distance from the center of gravity allow it to develop thrust in a direction opposite of the main rotor's rotation, to counter the torque effect created by the main rotor. Tail rotors are simpler than main rotors since they require only collective changes in pitch to vary thrust. The pitch of the tail rotor blades is adjustable by the pilot via the anti-torque pedals, which also provide directional control by allowing the pilot to rotate the helicopter around its vertical axis (thereby changing the direction the craft is pointed).

Ducted fan



Fenestron on a EC 120B

Fenestron and FANTAIL are trademarks for a ducted fan mounted at the end of the tail boom of the helicopter and used in place of a tail rotor. Ducted fans have between eight and 18 blades arranged with irregular spacing, so that the noise is distributed over different frequencies. The housing is integral with the aircraft skin and allows a high rotational speed, therefore a ducted fan can have a smaller size than a conventional tail rotor.

The Fenestron was used for the first time at the end of the 1960s on the second experimental model of Sud Aviation's SA 340, and produced on the later model Aérospatiale SA 341 Gazelle. Besides Eurocopter and its predecessors, a ducted fan tail rotor was also used on the canceled military helicopter project, the United States Army's RAH-66 Comanche, as the FANTAIL.

NOTAR

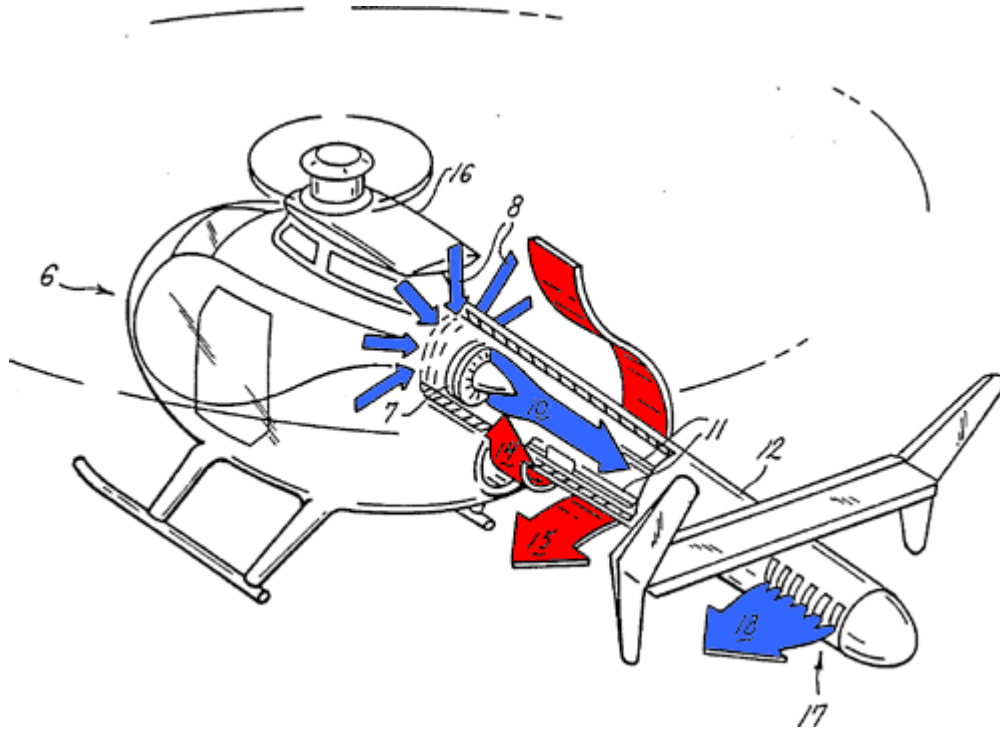

Diagram showing the movement of air through the NOTAR system

NOTAR, an acronym for *NO Tail Rotor*, is a helicopter anti-torque system that eliminates the use of the tail rotor on a helicopter. Although the concept took some time to refine, the NOTAR system is simple in theory and works to provide antitorque the same way a wing develops lift using the Coandă effect. A variable pitch fan is enclosed in the aft fuselage section immediately forward of the tail boom and driven by the main rotor transmission. This fan forces low pressure air through two slots on the right side of the tailboom, causing the downwash from the main rotor to hug the tailboom, producing lift, and thus a measure of antitorque proportional to the amount of airflow from the rotorwash. This is augmented by a direct jet thruster (which also provides directional yaw control) and vertical stabilizers.

Development of the NOTAR system dates back to 1975 when engineers at Hughes Helicopters began concept development work. In December 1981 Hughes flew a OH-6A fitted with NOTAR for the first time. A more heavily modified prototype demonstrator first flew in March 1986 and successfully completed an advanced flight-test program, validating the system for future application in helicopter design. There are currently three production helicopters that incorporate the NOTAR design, all produced by MD Helicopters. This antitorque design also improves safety by eliminating the possibility of personnel walking into the tail rotor.

Tip jets

Another single main rotor configuration without a tail rotor is the tip jet rotor, where the main rotor is not driven by the mast, but from nozzles on the rotor blade tips; which are either pressurized from a fuselage-mounted gas turbine or have their own turbojet, ramjet or rocket thrusters. Although this method is simple and eliminates torque, the prototypes that have been built are less fuel efficient than conventional helicopters and produced more noise. The Percival P.74 was underpowered and was not able to achieve flight, while the Hiller YH-32 Hornet had good lifting capability but performed poorly otherwise. Other aircraft relied on supplemental thrust so that the tipjets could be shut down and the rotor could autorotate after the fashion of an autogyro. The experimental Fairey Jet Gyrodyne and 40-seat Fairey Rotodyne passenger prototype were evaluated to have flown very well using this method. Perhaps the most unusual design of this type was the Rotary Rocket Roton ATV, which was originally envisioned to take off utilizing a rocket-tipped rotor. No tip jet rotorcraft have ever entered into production.

Dual rotors (counterrotating)

Counterrotating rotors are rotorcraft configurations with a pair or more of large horizontal rotors turning in opposite directions to counteract the effects of torque on the aircraft without relying on an antitorque tail rotor. This allows the power normally required to drive the tail rotor to be applied to the main rotors, increasing the aircraft's lifting capacity. Primarily, there are three common configurations that use the counterrotating effect to benefit the rotorcraft. Tandem rotors are two rotors with one mounted behind the other. Coaxial rotors are two rotors that are mounted one above the other with the same axis. Intermeshing rotors are two rotors that are mounted close to each other at a sufficient angle to allow the rotors to intermesh over the top of the aircraft. Another configuration found on tiltrotors and some earlier helicopters is called transverse rotors where the pair of rotors are mounted at each end of wing-type structures or outriggers.

Tandem



CH-47 Chinook

Tandem rotors are two horizontal main rotor assemblies mounted one behind the other. Tandem rotors achieve pitch attitude changes to accelerate and decelerate the helicopter through a process called differential collective pitch. To pitch forward and accelerate, the rear rotor increases collective pitch, raising the tail and the front rotor decreases collective pitch, simultaneously dipping the nose. To pitch upward while decelerating (or moving rearward), the front rotor increases collective pitch to raise the nose and the rear rotor decreases collective pitch to lower the tail. Yaw control is developed through opposing cyclic pitch in each rotor; to pivot right, the front rotor tilts right and the rear rotor tilts left, and to pivot left, the front rotor tilts left and the rear rotor tilts right. All of the rotor power contributes to lift, and it is simpler to handle changes in the center of gravity fore-aft. However, it requires the expense of two large rotors rather than the more common one large main rotor and a much smaller tail rotor. The CH-47 Chinook is the most common tandem rotor helicopter today.

Coaxial



Kamov Ka-50 of the Russian Air Force, with coaxial rotors

Coaxial rotors are a pair of rotors mounted one above the other on the same shaft and turning in opposite directions. The advantage of the coaxial rotor is that, in forward flight, the lift provided by the advancing halves of each rotor compensates for the retreating half of the other, eliminating one of the key effects of dissymmetry of lift: retreating blade stall. However, other design considerations plague coaxial rotors. There is an increased mechanical complexity of the rotor system because it requires linkages and swashplates for two rotor systems. Add that each rotor system needs to be turned in opposite directions means that the mast itself is more complex, and provisions for making pitch changes to the upper rotor system must pass through the lower rotor system.

Intermeshing



HH-43 Huskie

Intermeshing rotors on a helicopter are a set of two rotors turning in opposite directions, with each rotor mast mounted on the helicopter with a slight angle to the other so that the blades intermesh without colliding. This configuration is sometimes referred to as a synchropter. Intermeshing rotors have high stability and powerful lifting capability. The arrangement was successfully used in Nazi Germany for a small anti-submarine warfare helicopter, the Flettner Fl 282 Kolibri. During the Cold War, the American company, Kaman Aircraft produced the HH-43 Huskie for the USAF firefighting and rescue missions. The latest Kaman model, the Kaman K-MAX, is a dedicated sky crane design.

Transverse



Mi-12

Transverse rotors are mounted on the end of wings or outriggers, perpendicular to the body of the aircraft. Similar to tandem rotors and intermeshing rotors, the transverse rotor also uses differential collective pitch. But like the intermeshing rotors, the transverse rotors use the concept for changes in the roll attitude of the rotorcraft. This configuration is found on two of the first viable helicopters, the Focke-Wulf Fw 61 and the Focke-Achgelis Fa 223, as well as the world's largest helicopter ever built, the Mil Mi-12. It is also the configuration found on tiltrotors, such the Bell XV-15 and the newer Bell-Boeing V-22 Osprey.

Quadrotor

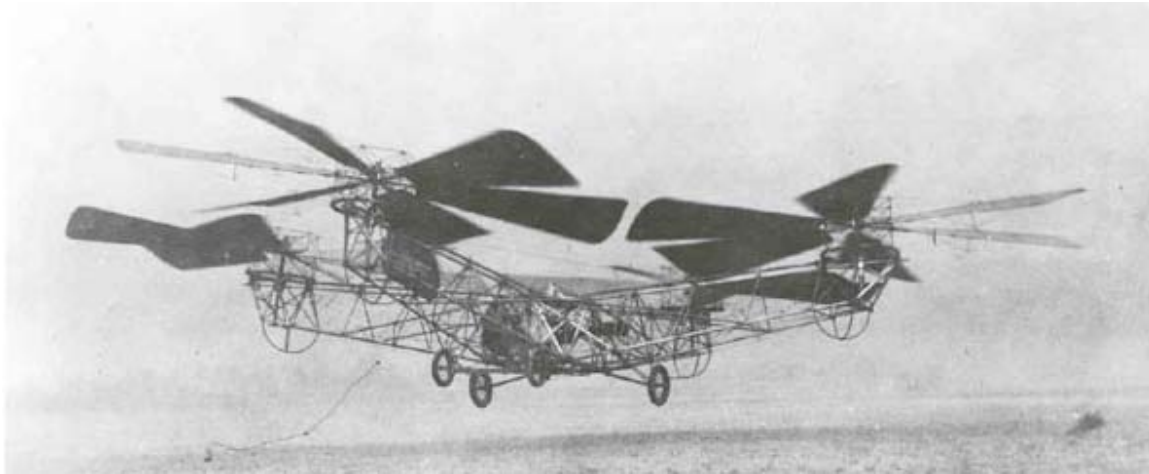

De Bothezat Quadrotor, 1923

A quadrotor helicopter has four rotors in an "X" configuration designated as front-left, front-right, rear-left, and rear-right. Rotors to the left and right are in a transverse configuration while those in the front and to the rear are in a tandem configuration.

The main attraction of quadrotors is their mechanical simplicity—a quadrotor helicopter using electric motors and fixed-pitch rotors uses only four moving parts.

Blade design

The blades of a helicopter are long, narrow airfoils with a high aspect ratio, a shape which minimises drag from tip vortices. They generally contain a degree of washout to reduce the lift generated at the tips, where the airflow is fastest and vortex generation would be a significant problem. Rotor blades are made out of various materials, including aluminium, composite structure and steel or titanium with abrasion shields along the leading edge. Rotorcraft blades are traditionally passive, but research into active blade control trailing edge flaps is performed.

Limitations and hazards

Helicopters with teetering rotors, for example the two-blade system on the Bell, Robinson and others, must not be subjected to a low-g condition because such rotor systems do not control the fuselage attitude. This can result in the fuselage assuming an attitude controlled by momentum and tail rotor thrust that causes the tail boom to intersect the main rotor tip-path plane, or result in the blade roots contacting the main rotor drive shaft causing the blades to separate from the hub (mast bumping).

Abrasion in sandy environments

When operating in sandy environments, sand hitting the moving rotor blades erodes their surface. This can damage the rotors; the erosion also presents serious and costly maintenance problems.

The abrasion strips on helicopter rotor blades are made of metal, often titanium or nickel, which are very hard, but less hard than sand. When a helicopter is flown near to the ground in desert environments abrasion occurs from the sand striking the rotor blade. At night, the sand hitting the metal abrasion strip causes a visible corona or halo around the rotor blades. The corona effect is caused by the oxidation of eroded particles resulting in visible corona.

In 2009, war correspondent Michael Yon referred to this corona effect as "Kopp-Etchells effect", to honor Cpl. Benjamin Kopp, and Cpl. Joseph Etchells, recently fallen American and British soldiers, respectively.

Chapter- 4

Specific Types of Helicopters

Agusta A.101

A.101



A.101 helicopter in 1964. Third from right is Count Domenico Agusta and fourth is Filippo Zappata

Role	Transport helicopter
Manufacturer	Agusta
Designed by	Filippo Zappata
First flight	19 October 1964
Number built	1

The **Agusta A.101** (originally designated **AZ.101**) was a large prototype transport helicopter developed in Italy during the course of the 1960s. Despite prospective orders from the Italian armed forces, no buyers emerged and the project was abandoned in 1971.

The A.101 was of conventional, single-rotor configuration with tricycle undercarriage and powered by triple turboshaft engines. The fuselage was provided with a rear loading ramp and two large sliding troop doors.

The final stage in the A.101's development was to stretch the fuselage by 3 m (10 ft) and upgrade the engines to the more powerful General Electric T58. This resulted in a marked improvement in performance, but in the end, the Italian government opted for variants of the SH-3 Sea King, licence-built by Agusta instead of their own design.

The single prototype is preserved at the Museo Agusta at Cascina Costa.

Specifications (AZ.101G configuration)

General characteristics

- **Crew:** two pilots
- **Capacity:** 35 passengers *or* 5,000 kg (11,000 lb) cargo *or* 18 stretchers and 5 attendants
- **Length:** 20.2 m (66 ft 3 in)
- **Main rotor diameter:** 19.8 m (64 ft 11 in)
- **Height:** 6.6 m (21 ft 8 in)
- **Main rotor area:** 308 m² (3,314 ft²)
- **Empty weight:** 6,400 kg (14,000 lb)
- **Gross weight:** 11,500 kg (25,000 lb)
- **Powerplant:** 3 × Rolls-Royce Gnome H1400 turboshafts, 1,030 kW (1,380 hp) each

Performance

- **Maximum speed:** 225 km/h (140 mph)
- **Range:** 383 km (239 miles)
- **Service ceiling:** 3,950 m (13,000 ft)
- **Rate of climb:** 12.3 m/s (2,420 ft/min)

Agusta A.103

A.103



Role	Light helicopter
Manufacturer	Agusta
First flight	1959

The **Agusta A.103** was an Italian prototype single-seat light helicopter flown in October 1959. The pilot was enclosed by a perspex bubble with the engine at the rear and the tail rotor carried on an enclosed boom.

Specifications

General characteristics

- **Crew:** one, pilot
- **Length:** 6.13 m (20 ft 1 in)
- **Main rotor diameter:** 7.4 m (24 ft 3 in)
- **Height:** 2.3 m (7 ft 7 in)
- **Main rotor area:** 43 m² (463 ft²)
- **Gross weight:** 460 kg (1,000 lb)
- **Powerplant:** 1 × Agusta GA.70, 64 kW (85 hp)

Performance

- **Maximum speed:** 150 km/h (90 mph)
- **Range:** 450 km (280 miles)
- **Service ceiling:** 2,000 m (6,600 ft)

Bell 427

Bell 427



Croatian Bell-427 landing

Role	Multipurpose utility helicopter
National origin	United States Canada
Manufacturer	Bell Helicopter Samsung Aerospace Industries (later part of Korea Aerospace Industries)
First flight	11 December 1997
Introduced	2000
Status	Active service
Developed from	Bell 407
Variants	Bell 429

The **Bell Model 427** is a twin engine, multirole, light utility helicopter designed and manufactured by Bell Helicopter and Samsung Aerospace Industries. Its design is based on Bell 407. It was replaced in production by the lengthened Bell 429.

Development

Bell has tried several incarnations of a twin version of its successful Bell 206 series, including the stillborn *Bell 400* and *440* of the mid 1980s, and the limited production *Bell 206LT TwinRanger* of the early 1990s. Bell's original concept for a replacement for the 206LT TwinRanger was the *Bell 407T*, a relatively straightforward twin engine development of the *Bell 407* with two Allison 250-C22B engines. However, Bell concluded that the payload/range performance of the 407T would not be sufficient.

The company began development of a new light twin, in partnership with South Korea's Samsung Aerospace Industries. In February 1996, Bell announced its **Model 427** at the Heli Expo in Dallas. The Bell 427 was the company's first aircraft designed entirely on computer. The Bell 427 first flew on December 11, 1997. Canadian certification was awarded on November 19, 1999, followed by US certification in January 2000, and US FAA dual pilot IFR certification in May 2000. Bell builds the 427's flight dynamics systems at Fort Worth, Texas, while final assembly is performed at Bell's Mirabel, Quebec facility. The 427's fuselage and tailboom are built by Samsung (later part of KAI) at its Sachon plant in South Korea. The first customer deliveries occurred in January 2000.

In 2004, Bell offered a redesigned 427 version, the **Bell 427i**, which was developed in partnership with South Korea's Korea Aerospace Industries and Japan's Mitsui Bussan Aerospace. The agreement gave KAI the development and production responsibility for the fuselage, cabin wiring, and fuel system. Mitsui Bussan became a financial backer. The 427i included a newer glass cockpit and navigation systems to allow single pilot flying under Instrument flight rules. The design had a fuselage lengthened 1 ft 2 in (0.36 m), a more powerful engine version and transmission, and increased takeoff weight. However, the program was canceled and focus shifted to the improved Bell 429. In February 2005, the existing 80 orders for the 427i were converted to the 429. On January 24, 2008, Bell announced plans to officially discontinue its 427 line after current order commitments are fulfilled in 2010.

Design



Bell-427 cockpit

The Bell 427 is powered by two Pratt & Whitney Canada PW207D turboshaft engines with FADEC. Like the Bell 407, the 427 uses a 4-blade main rotor system with a rigid, composite rotor hub and a 2-blade tail rotor.

The Bell 427's cabin is 13 in (33 cm) longer than the 407, and is largely of composite construction. The cabin lacks the roof beam which obstructs the cabin on the 206/206L/407, and has an optional sliding main cabin door.

The 427 offers 8-place seating including pilot in a 2+3+3 arrangement. Alternate layouts include four in the main cabin in a club configuration, or two stretchers and two medical attendants for medical evacuation duties.

Operators

-  Argentina
 - Entre Rios Police
-  Bahrain

- Bahrain Public Security Force
-  Czech Republic
 - Czech HEMS - Alfa Helicopter

Specifications (Bell 427)

General characteristics

- **Crew:** 2 pilots
- **Capacity:** 7 passengers
- **Length:** 37 ft 6 in (11.42 m)
- **Rotor diameter:** 37 ft 0 in (11.28 m)
- **Height:** 10 ft 6 in (3.20 m)
- **Disc area:** 1,075 ft² (99.9 m²)
- **Empty weight:** 3,881 lb (1,760 kg)
- **Useful load:** 2,960 lb (1,340 kg; for internal load)
- **Max takeoff weight:** 6,550 lb (2,970 kg)
- **Powerplant:** 2× Pratt & Whitney Canada PW207D turboshaft, 710 hp (529 kW) each

Performance

- **Maximum speed:** 140 knots (161 mph, 259 km/h)
- **Cruise speed:** 138 knots (159 mph, 256 km/h)
- **Range:** 394 nmi (342 mi, 730 km)
- **Service ceiling:** 10,000 ft (3,048 m)
- **Rate of climb:** 2,000 ft/min (10.16 m/s)

Bell H-12

R-12 (Model 48)



YR-12B / YH-12B

Role	five/eight seat utility helicopter
Manufacturer	Bell Helicopter
First flight	1946
Status	pre-series
Primary user	United States Air Force
Number built	13
Developed from	Bell 47

The **Bell R-12 (Model 48)** was an American 1940s military utility helicopter built by Bell Helicopter company.

Development

During 1946 Bell Helicopter began development of a new helicopter, much larger, than Model 47. It was partly basing upon its construction, first of all, a rotor system, and was basically a scaled-up version of Model 47. The basic variant was civilian Model 42, but the United States Air Force got interested in the design and ordered development of its military variant, **Model 48**. Two prototypes were ordered as the **XR-12**. It was powered by a 540 hp Pratt & Whitney R-1340-AN-1 radial engine and seated five. A production batch of 34 helicopters was ordered, under a designation **R-12A**, but it was cancelled afterwards. Another enlarged prototype (the **XR-12B**, Model 48A) with seats for eight and a more powerful 600 hp R-1340-55 engine was also ordered. It was followed by ten pre-series helicopters **YR-12B**, with a redesigned cabin, with a glazed nose, instead of car-like nose. With a change in designation system the helicopter was re-designated the

H-12. Test were not satisfactory, there were initially problems with a main rotor, and none were ordered.

Variants

XR-12

prototype, redesignated XH-12, two built.

R-12A

production version, 34 on order cancelled.

XR-12B

prototype with more powerful engine and increased seating, re-designated XH-12B, one built.

YR-12B

as XR-12B but with R-1340-55 engines, re-designated YH-12B, ten built.

XH-12

XR-12 re-designated in 1947.

XH-12B

XR-12B re-designated in 1947.

YH-12B

YR-12B re-designated in 1947.

Operators

 United States

- United States Air Force

Specifications (XR-12B)

General characteristics

- **Crew:** 2
- **Capacity:** 8
- **Length:** ft (12.06 m)(fuselage)
- **Rotor diameter:** 47 ft 6 in (14.48 m)
- **Height:** ft (3.43 m)
- **Disc area:** 1,772 ft² (164.62 m²)
- **Loaded weight:** lb (2854 kg)
- **Max takeoff weight:** 6,286 lb (2851 kg)
- **Powerplant:** 1× Pratt & Whitney R-1340-55 Wasp radial piston, 600 hp (447 kW)
- **Propellers:** 1 rotor, 1 per engine

Performance

- **Maximum speed:** 105 mph (169 km/h)
- **Cruise speed:** 90 mph (145 km/h)
- **Range:** 300 miles (483 km)
- **Service ceiling:** ft (3960 m)
- **Rate of climb:** ft/s (2.28 m/s)

Chapter- 5

Autogyro



An **autogyro** (in Spanish **autogiro**), also known as **gyroplane**, **gyrocopter**, or **rotaplane**, is a type of rotorcraft which uses an unpowered rotor in autorotation to develop lift, and an engine-powered propeller, similar to that of a fixed-wing aircraft, to provide thrust. While similar to a helicopter rotor in appearance, the autogyro's rotor must have air flowing through the rotor disc in order to generate rotation. Invented by the Spanish engineer Juan de la Cierva to create an aircraft that could safely fly at slow speeds, the autogyro was first flown on 9 January 1923, at Cuatro Vientos Airfield in Madrid. De la Cierva's aircraft resembled the fixed-wing aircraft of the day, with a front-mounted engine and propeller in a tractor configuration to pull the aircraft through the air. Late-model autogyros patterned after Dr. Igor Bensen's designs feature a rear-mounted engine and propeller in a pusher configuration. The term *Autogiro* was a trademark of the Cierva Autogiro Company, and the term *Gyrocopter* was used by E. Burke Wilford who developed the Reiseler Kreiser feathering rotor equipped gyroplane in the first half of the twentieth century. The latter term was later adopted as a trademark by Bensen Aircraft.

Configuration

An autogyro is characterized by a free-spinning rotor that turns because of passage of air upward through the rotor. The vertical component of the total aerodynamic reaction of the rotor gives lift for the vehicle, and sustains the autogyro in the air. A separate propeller provides forward thrust, and can be placed in a tractor configuration with the engine and propeller at the front of the fuselage (e.g., Cierva), or pusher configuration with the engine and propeller at the rear of the fuselage (e.g., Bensen).

Whereas a helicopter works by forcing the rotor blades through the air, pushing air downwards, the autogyro rotor blade generates lift in the same way as a glider's wing by changing the angle of the air as it moves upwards and backwards relative to the rotor blade. The free-spinning blades turn by autorotation; the rotor blades are angled so that they not only give lift, but the angle of the blades causes the lift to accelerate the blades' rotation rate, until the rotor turns at a stable speed with the drag and thrust forces in balance.



The rotor head, pre-rotator shaft and Subaru engine configuration on a VPM M-16 autogyro

Pitch control of the autogyro is by tilting the rotor fore and aft; roll control is by tilting the rotor laterally (side to side). Three designs to affect the tilt of the rotor are a tilting hub (Cierva), swashplate (Air & Space 18A), or servo-flaps (Kaman SAVER). A rudder provides yaw control. On pusher configuration autogyros, the rudder is typically placed in the propeller slipstream to maximize yaw control at low airspeed (but not always, as seen in the McCulloch J-2, with twin rudders placed outboard of the propeller arc).

Flight controls

There are three primary flight controls: control stick, rudder pedals, and throttle. The control stick is termed *cyclic* and tilts the rotor in the desired direction to provide pitch and roll control. The rudder pedals provide yaw control, and the throttle controls engine power.

Secondary flight controls include the rotor transmission clutch, also known as a pre-rotator, which when engaged drives the rotor to start it spinning before takeoff, and collective pitch to reduce blade pitch before driving the rotor. Collective pitch controls are not usually fitted to autogyros, but can be found on the Air & Space 18A and McCulloch J-2 and the Westermayr Tragschrauber and are capable of near VTOL performance. Unlike a helicopter, autogyros without collective pitch need a runway to takeoff; however they are capable of landing with a very short, or zero ground roll.

Pusher vs tractor configuration



Montgomery Merlin single-seat autogyro

Modern autogyros typically follow one of two basic configurations. The most common design is the pusher configuration, where the engine and propeller are located behind the

pilot and rotor mast, such as in the Bensen "Gyrocopter". It was developed by Igor Bensen in the decades following World War II, and came into widespread use shortly afterward.

Less common today is the tractor configuration. In this version the engine and propeller are located at the front of the aircraft, ahead of the pilot and rotor mast. This was the primary configuration in early autogyros, but became less common after the advent of the helicopter. It has enjoyed a revival since the mid 1970s.

History

Juan de la Cierva was a Spanish engineer and aeronautical enthusiast. In 1921, he participated in a design competition to develop a bomber for the Spanish military. De la Cierva designed a three-engined aircraft, but during an early test flight, the bomber stalled and crashed. De la Cierva was troubled by the stall phenomenon and vowed to develop an aircraft that could fly safely at low airspeeds. The result was the first successful rotorcraft, which he named *Autogiro* in 1923. De la Cierva's autogyro used an airplane fuselage with a forward-mounted propeller and engine, a rotor mounted on a mast, and a horizontal and vertical stabilizer.

Early development

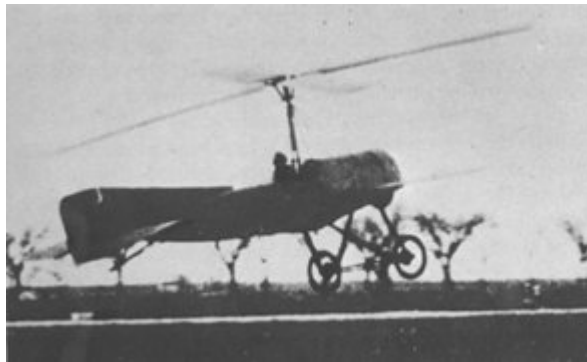

The first autogyro to fly successfully (1923)



Cierva C.6 replica in Cuatro Vientos Air Museum, Madrid, Spain



Royal Air Force Avro Rota Mk 1 Cierva Autogyro C30 A, at the Imperial War Museum Duxford, UK.

De la Cierva's first three designs (C.1, C.2, and C.3) were unstable because of aerodynamic and structural deficiencies in their rotors. His fourth design, the C.4, made the first successful flight of an autogyro on 9 January 1923, piloted by Alejandro Gomez Spencer at Cuatro Vientos airfield in Madrid, Spain. De la Cierva had fitted the rotor of the C.4 with flapping hinges to attach each rotor blade to the hub. The flapping hinges allowed each rotor blade to flap, or move up and down, to compensate for dissymmetry of lift, the difference in lift produced between the right and left sides of the rotor as the autogyro moves forward. Three days later, the engine failed shortly after takeoff and the aircraft descended slowly and steeply to a safe landing, validating De la Cierva's efforts to produce an aircraft that could be flown safely at low airspeeds.

De la Cierva developed his C.6 model with the assistance of Spain's Military Aviation establishment, having expended all his funds on development and construction of the first five prototypes. The C.6 first flew in February 1925, including a flight of 10.5 km (7 miles) from Cuatro Vientos airfield to Getafe airfield in about 8 minutes, a significant accomplishment for any rotorcraft of the time. Shortly after De la Cierva's success with the C.6, Cierva accepted an offer from Scottish industrialist James G. Weir to establish the Cierva Autogyro Company in England, following a demonstration of the C.6 before

the British Air Ministry at RAE Farnborough, on 20 October 1925. Britain had become the world centre of autogyro development.

A crash in February 1927, caused by blade root failure, led to an improvement in rotor hub design. A drag hinge was added in conjunction with the flapping hinge to allow each blade to move fore and aft and relieve in-plane stresses, generated as a byproduct of the flapping motion. This development led to the Cierva C.8, which, on 18 September 1928, made the first rotorcraft crossing of the English Channel followed by a tour of Europe.

The U.S. industrialist Harold Frederick Pitcairn, upon learning of the successful flights of the autogyro, had previously visited De la Cierva in Spain. In 1928 he visited him again, in England, after taking a C.8 L.IV test flight piloted by Arthur H.C.A. Rawson. Being particularly impressed with the autogyro's safe vertical descent capability, Pitcairn purchased a C.8 L.IV with a Wright Whirlwind engine. Arriving in the United States on 11 December 1928 accompanied by Rawson, this autogyro was redesignated C.8W. Subsequently, production of autogyros was licensed to a number of manufacturers, including the Pitcairn Autogyro Company in the U.S. and Focke-Wulf of Germany.



Avro-built Cierva C.19 Mk.IV Autogyro, built in 1932. Cuatro Vientos Airport Museum, Madrid, Spain.

In 1927 Engelbert Zaschka, a pioneering German engineer, invented a combined helicopter and autogyro. The principal advantage of the Zaschka machine is in its ability

to remain motionless in the air for any length of time and to descend in a vertical line, so that a landing may be accomplished on the flat roof of a large house. In appearance, the machine does not differ much from the ordinary monoplane, but the carrying wings revolve around the body.

Development of the autogyro continued in search for a means to accelerate the rotor prior to takeoff (called prerotating). Rotor drives initially took the form of a rope wrapped around the rotor axle and then pulled by a team of men to accelerate the rotor - this was followed by a long taxi to bring the rotor up to speed sufficient for takeoff. The next innovation was flaps on the tail to redirect the propeller slipstream into the rotor while on the ground. This design was first tested on a C.19 in 1929. Efforts in 1930 had shown that development of a light and efficient mechanical transmission was not a trivial undertaking. But in 1932, the Pitcairn-Cierva Autogyro Company of Willow Grove, Pennsylvania, finally solved the problem with a transmission driven by the engine.

De la Cierva's early autogyros were fitted with fixed rotor hubs, small fixed wings, and control surfaces like those of a fixed wing aircraft. At low airspeeds, the control surfaces became ineffective and could readily lead to loss of control, particularly during landing. In response, Cierva developed a direct control rotor hub, which could be tilted in any direction by the pilot. De la Cierva's direct control was first developed on the Cierva C.19 Mk. V and saw production on the Cierva C.30 series of 1934. In March 1934 this type of autogyro became the first rotorcraft to take off and land on the deck of a ship, when a C.30 performed trials onboard the Spanish navy seaplane tender *Dédalo* off Valencia.

Later that year, during the leftist Asturias' revolt in October, an autogyro made a reconnaissance flight for the loyal troops, marking the first military employment of a rotorcraft.

When improvements in helicopters made them practical, autogyros became largely neglected. They were, however, used in the 1930s by major newspapers, and by the US Postal Service for mail service between the Camden, NJ airport (USA) and the top of the post office building in downtown Philadelphia, Pennsylvania (USA).

World War II

In World War II, Germany pioneered a very small gyroglider rotor kite, the Focke-Achgelis Fa 330 "Bachstelze" (Water-wagtail), towed by U-boats to provide aerial surveillance.

The Imperial Japanese Army developed the Kayaba Ka-1 Autogyro for reconnaissance, artillery-spotting, and anti-submarine uses. The Ka-1 was based on an American design first imported to Japan in 1938. The craft was initially developed for use as an observation platform and for artillery spotting duties. The Army liked the craft's short take-off span, and especially its low maintenance requirements. In 1941 production began, with the machines assigned to artillery units for spotting the fall of shells. These carried two crewmen: a pilot and a spotter.

Later, the Japanese Army commissioned two small aircraft carriers intended for coastal antisubmarine (ASW) duties. The spotter's position on the Ka-1 was modified in order to carry one small depth charge. Ka-1 ASW autogyros operated from shore bases as well as the two small carriers. They appear to have been responsible for at least one submarine sinking.

The autogyro was used to calibrate the coastal radar stations during and after the Battle of Britain.

Postwar developments

The autogyro was resurrected after World War II when Dr. Igor Bensen, a Russian immigrant, saw a captured German U-Boat's Fa 330 gyroglider and was fascinated by its characteristics. At work he was tasked with the analysis of the British military "Rotachute" gyro glider designed by expatriate Austrian Raoul Hafner. This led him to adapt the design for his own purposes and eventually market the B-7. Bensen submitted an improved version, the Bensen B-8M, for testing to the United States Air Force, which designated it the X-25. The B-8M was designed to use surplus McCulloch engines used on flying unmanned target drones.

Ken Wallis developed a miniature autogyro craft, the *Wallis* autogyro, in England in the 1960s, and autogyros built similar to Wallis' design appeared for a number of years. Ken Wallis' designs have been used in various scenarios including military training, police reconnaissance, and in another case a search for the Loch Ness Monster.

Three different autogyro designs have been certified by the Federal Aviation Administration for commercial production: the Umbaugh U-18/Air & Space 18A of 1965, the Avian 2-180 Gyroplane of 1967, and the McCulloch J-2 of 1972. All have been commercial failures, for various reasons.

Bensen Gyrocopter

The basic Bensen *Gyrocopter* design is a simple frame of square aluminium or galvanized steel tubing, reinforced with triangles of lighter tubing. It is arranged so that the stress falls on the tubes, or special fittings, not the bolts. A front-to-back keel mounts a steerable nosewheel, seat, engine, and a vertical stabilizer. Outlying mainwheels are mounted on an axle. Some versions may mount seaplane-style floats for water operations.



Bensen Aircraft B8MG Gyrocopter

Bensen-type autogyros use a pusher configuration for simplicity and to increase visibility for the pilot. Power can be supplied by a variety of engines. McCulloch drone engines, Rotax marine engines, Subaru automobile engines, and other designs have been used in Bensen-type designs.

The rotor is mounted atop the vertical mast. The rotor system of all Bensen-type autogyros is of a two-blade teetering design. There are some disadvantages associated with this rotor design, but the simplicity of the rotor design lends itself to ease of assembly and maintenance and is one of the reasons for its popularity. Aircraft-quality birch was specified in early Bensen designs, and a wood/steel composite is used in the world speed record holding Wallis design. Gyroplane rotor blades are made from other materials such as aluminium and GRP-based composite blades.

Because of Bensen's pioneering of the concept and the popularity of his design, "Gyrocopter" has become a genericized trademark for pusher configuration autogyros.

Certification by national aviation authorities

US certification

A certificated autogyro must meet mandated stability and control criteria; in the United States these are set forth in *Federal Aviation Regulations Part 27: Airworthiness*

Standards: Normal Category Rotorcraft. The U.S. Federal Aviation Administration issues a Standard Airworthiness Certificate to qualified autogyros. Amateur-built or kit-built aircraft are operated under a Special Airworthiness Certificate in the Experimental category. Per FAR 1.1, the FAA uses the term "gyroplane" for all autogyros, regardless of the type of Airworthiness Certificate.

UK certification



A VPM M-16 commences its take-off roll

Some autogyros, such as the Rotorsport MT03, have type approval by the United Kingdom Civil Aviation Authority (CAA) under British Civil Airworthiness Requirements CAP643 Section T. Others operate under a permit to fly issued by the Popular Flying Association— similar to the US experimental aircraft certification. However, the CAA's assertion that autogyros have a poor safety record means that permit to fly will only be granted to existing types of autogyro. All new types of autogyro must be submitted for full type approval under CAP643 Section T.

In 2005, the CAA issued a mandatory permit directive (MPD) which restricted operations for single seat autogyros, and were subsequently integrated into CAP643 Issue 3 published on 12 August 2005. The restrictions are concerned with the offset between the centre of gravity and thrust line, and apply to all aircraft unless evidence is presented to the CAA that the CG/Thrust Line offset less than 2 inches (5 cm) in either direction. The restrictions are summarised as follows:

- Aircraft with a cockpit/nacelle may only be operated by pilots with more than 50 hours solo flight experience following the issue of their licence.
- Open frame aircraft are restricted to a minimum speed of 30 mph (26 knots), except in the flare.
- All aircraft are restricted to a Vne of 70 mph (61 knots)
- Flight is not permitted when surface winds exceed 17 mph (15 knots) or if the gust spread exceeds 12 mph (10 knots)
- Flight is not permitted in moderate, severe or extreme turbulence and airspeed must be reduced to 63 mph (55 knots) if turbulence is encountered mid-flight.

World records

In 1931, Amelia Earhart flew a Pitcairn PCA-2 to a women's world altitude record of 18,415 ft (5,613 m).

Wing Commander Ken Wallis has held most of the autogyro world records during his autogyro flying career. These include the speed record of 186 km/h (111.7 mph), and the straight-line distance record of 869.23 km (543.27 miles). On 16 November 2002, at 89 years of age, Wallis increased the 3km speed record to 207.7 km/h (129.1 mph) - and simultaneously set another world record as the oldest pilot to set a world record.

The autogyro is one of the last remaining types of aircraft which has not yet been used to circumnavigate the globe. Expedition Global Eagle was the first attempt in history to circumnavigate the globe using an autogyro. The expedition set the record for the longest flight over water by an autogyro during the segment from Muscat, Oman to Karachi. The attempt was finally abandoned because of bad weather after a trip totalling 7,500 miles (12,100 km).

In February 2003, a year before the circumnavigation attempt, the *Global Eagle* piloted by Warrant Officer Barry Jones also broke the world range record by flying non-stop from Cudrose in Cornwall to Wick in Scotland, a total of 580 miles (928 km) breaking the old record held by Wing Commander Ken Wallis.

Andrew Keech made a transcontinental flight from Kitty Hawk, North Carolina to San Diego, California in October 2003 and set 3 world records for speed over a recognized course. The 3 records were verified by tower personnel or by official observers of the United States' National Aeronautic Association (NAA). On 9 February 2006, he broke two of his world records and set a record for distance, ratified by the Fédération Aéronautique Internationale (FAI); Speed over a closed circuit of 500 km (311 mi)

without payload: 168.29 km/h (104.57 mph), speed over a closed circuit of 1,000 km (621 mi) without payload: 165.07 km/h (102.57 mph), and distance over a closed circuit without landing: 1,019.09 km (633.23 mi).

Chapter- 6

Types of Autogyro

Cierva C.30

C.30



Avro 671 Rota Mk 1 at Imperial War Museum, Duxford

Role	Autogyro
Designed by	Juan de la Cierva
First flight	1933
Introduced	1934
Number built	148
Variants	Cierva C.40

The **Cierva C.30** was an autogyro designed by Juan de la Cierva and built under licence from the Cierva Autogyro Company by A V Roe & Co Ltd (Avro), Lioré-et-Olivier and Focke-Wulf.

Design and development

Before the experimental Cierva C.19 Mk V, autogyros had been controlled in the same way as fixed wing aircraft, that is by deflecting the air flowing over moving surfaces such

as ailerons, elevators and rudder. At the very low speeds encountered in autogiro flight, particularly during landing, these controls became ineffective. The experimental machine showed that the way forward was to have a tilting rotor hub and a control rod coming down from the hub to the pilot's cockpit with which he could change the rotor plane. This was known as "direct control" and was fitted to the **C.30**. The production variant, called **C.30A** in England, was preceded by several development machines.

The first production design in the series was the **C.30**, a radial engine autogiro with a three blade, 37 ft (11.3 m) rotor mounted on an aft-leaning tripod, the control column extending into the rear of the two cockpits. The engine was the five-cylinder, 105 hp (78 kW) Armstrong Siddeley Genet Major I used in the **C.19** series. The fabric covered fuselage carried an unbraced tailplane, without elevators but with turned up tips. The port side plane had an inverted aerofoil section to offset the roll-axis torque produced in forward flight by the advancing port side blades. As with most autogiros, a high vertical tail was precluded by the sagging resting rotor, so the dorsal fin was long and low, extending well aft of the tailplane like a fixed rudder and augmented by a ventral fin. The wide track undercarriage had a pair of single, wire braced legs and a small tail wheel was fitted. This model flew in April 1933. It was followed by four improved machines designated **C.30P** (P here for pre-production) which differed in having a four-legged pyramidal rotor mounting and a reinforced undercarriage with three struts per side. The rotor could be folded rearwards for transport. The **C.30P** used the more powerful (140 hp, 104 kW) seven-cylinder Armstrong Siddeley Genet Major IA radial engine.



Avro 671 (Cierva C.30A) taxiing for take-off at Rearsby Aerodrome in June 1951

The production model, called the C.30A by Avro, was built under licence in Britain, France and Germany and was similar to the C.30P. The main alteration was a further increase in undercarriage track with revised strutting, the uppermost leg having a pronounced knee with wire bracing. There was additional bracing to the tailplane and both it and the fin carried small movable trimming surfaces. Each licensee used nationally built engines and used slightly different names. In all, 143 production C.30s were built, making it by far the most numerous pre-war autogiro.

Between 1933 and 1936, de la Cierva used one C.30A (*G-ACWF*) to perfect his last contribution to autogiro development before his death in a DC-2 (fixed wing) crash in late 1936. To enable the aircraft to take off without forward ground travel, he produced the "Autodynamic" rotor head, which allowed the rotor to be spun up by the engine in the usual way but to higher than take-off r.p.m at zero rotor incidence and then to reach operational positive pitch suddenly enough to jump some 20 ft (6 m) upwards.

At least one of the RAF C.30As was in January 1935 on floats as a Sea Rota.

Production

Avro

Avro obtained the licence in 1934 and subsequently built 78 examples, under their model designation, fitted with an Armstrong Siddeley Genet Major IA (known in the RAF as the Civet 1) 7-cylinder radial engine producing 140 hp (100 kW). The first production C.30A was delivered in July 1934.

Lioré-et-Olivier

Twenty-five aircraft were built in France by Lioré-et-Olivier as the LeO C.301 with a 175 hp (130 kW) Salmson 9NE 9-cylinder radial engine.

Focke-Wulf

Forty aircraft were built in Germany by Focke-Wulf as the C 30 Heuschrecke (Grasshopper) with a 140 hp (105 kW) Siemens Sh 14A 7-cylinder radial engine.

Operational history

Of the 66 non-RAF aircraft built in the UK by Avro, 37 appeared at least for a while on the UK register. Some (maybe a dozen) were sold on abroad, but others were flown by wealthy enthusiasts and by flying clubs who anticipated autogiro training needs. By the end of the decade private flyers were moving back to the comforts and economies of fixed wing aircraft and more C.30s moved abroad, leaving the Autogiro Flying Club at London Air Park, Hanworth as the major UK user. 26 aircraft were directly exported by

Avro. These went both to private owners and to foreign air forces who wish to investigate the autogiro's potential.

In 1934, one Spanish navy C.30 piloted by Cierva landed on the Spanish Seaplane tender *Dedalo* anchored in Valencia harbor and later made a takeoff.

Twelve C.30A built by Avro for the Royal Air Force (RAF) entered service as the **Avro 671 Rota Mk 1** (Serials *K4230* to *K4239* and *K4296* & *K4775*). The twelve were delivered between 1934 to 1935. They equipped the Army School of Co-operation at Old Sarum near Salisbury.

Many of the surviving civil aircraft were also taken into RAF service between 1939 and 1940. In 1940 they equipped No. 1448 Flight at RAF Duxford. Later they equipped No. 529 Squadron RAF at Halton on radar calibration work. They disbanded in October 1945. At the end of the war the twelve survivors were sold.

Most of these did not last long, although two were used for pilot rotary wing experience by Fairey in their Fairey Gyrodyne helicopter programme. Rota Towels kept one ex-RAF Rota airworthy *G-AHTZ* until an accident in 1958. *G-ACUU*, the Imperial War Museum's C.30A exhibit at Duxford had one of the longest active lives. It joined Air Service Training Ltd in 1934, was impressed (as Rota *HM580*) in 1942, serving with 529 Squadron and returning to civil use by G.S. Baker based at Birmingham's Elmdon airport with its original registration plus the nickname *Billy Boy* and was not withdrawn from use until 1960.

Variants

C.30

Powered by a 78-kW (105-hp) Armstrong Siddeley Genet Major I radial piston engine.

C.30P

Improved model, powered by a 104-Kw (140-HP) Armstrong Siddeley Genet Major IA radial piston engine.

C.30A

Main production model, powered by a 104-kW (140-hp) Armstrong Siddeley Genet Major IA radial piston engine.

Rota Mk I

RAF designation of the Cierva C.30A.

Survivors

There are no flying survivors

Non flying

Avro Rota I (K4232)

On display at the Royal Air Force Museum, London, England.

Cierva C.30A (AP506)

On display at the Helicopter Museum, Weston-super-Mare, England.

Cierva C.30A (AP507)

On display at the Science Museum in London, England.

Avro Rota I (HM580 / G-ACUU)

On display at the Imperial War Museum Duxford, England.

Cierva C.30A (LN-BAD)

On display at the Aviodome, Netherlands.

Cierva C.30A (LV-FBL)

On display in Argentina.

Cierva C.30A (VH-USR)

On display at the Powerhouse Museum, Sydney, Australia.

Leo C.302 (F-BDAD)

On display at the Musée de l'Air et de l'Espace, Paris, France.

Cierva C.30A (H-KX)

On display at the Fantasy of Flight Museum, Florida, USA.

Cierva C.30 (I-CIER)

on display at the Museo della Scienza e della Tecnologia "Leonardo da Vinci", Milan, Italy.

In addition, a full-scale flying reproduction was built in Spain in the mid-1990s. After a brief flying career a crosswind accident led to the damage to the rare rotor blades. The aircraft is now on display at the Museo del Aire, Cuatro Vientos, Madrid, Spain.

Military operators

 Argentina

 Austria

 Belgium

 Denmark

 Italy

 Soviet Union

 Spanish Republic

 United Kingdom

- Royal Air Force

- No. 80 Squadron RAF
- No. 529 Squadron RAF

 Kingdom of Yugoslavia

Specifications (C.30A)

General characteristics

- **Crew:** one, pilot
- **Length:** 19 ft 8 in (6 m)
- **Rotor diameter:** 37 ft (11.28 m)
- **Height:** 11 ft 1 in (3.38 m)
- **Empty weight:** 1,220 lb (554.5 kg)
- **Loaded weight:** 1,800 lb (818 kg)
- **Powerplant:** 1× Armstrong Siddeley Genet Major IA 7-cylinder air-cooled radial engine, 140 hp (104 kW)

Performance

- **Maximum speed:** 110 mph (177 km/h)
- **Cruise speed:** 95 mph (153 km/h)
- **Range:** 285 mi (458 km)
- **Rate of climb:** 700 ft/min (213.4 m/min)

Cierva C.6

C.6



Cierva C.6 replica in Cuatro Vientos Air Museum,
Madrid, Spain

Role	Autogyro
Manufacturer	Cierva
Designed by	Juan de la Cierva
First flight	March 1924
Number built	1
Developed from	Cierva C.5



Cierva C.6 replica engine closeup

The **Cierva C.6** was the sixth autogyro designed by engineer Juan de la Cierva, and the first one to travel a "major" distance. Cierva, the engineer responsible for the invention of the autogyro, had spent all his funds in the research and creation of his first five prototypes. So, in 1923, he turned to the Cuatro Vientos Aerodynamics Laboratory chief, Commander Emilio Herrera, who succeeded in persuading General Francisco Echagüe, the director of the Military Aviation Aeronautics Department, to take over the second stage in the research and development of Cierva's Autogyros.

After several wind tunnel tests, Military Aviation built a Cierva C.6 autogyro in an Avro 504 frame. This machine, piloted by Captain Joaquín Loriga Taboada, performed three flights, all of them in March 1924. One of those flights, the eight minute trip from Cuatro Vientos airfield to Getafe airfield (10.5 km / 7 miles), was considered a giant's step and the "leap into glory" of Cierva's autogyros.

The Cierva C.6 prototype was fitted with ailerons mounted in two small wings, elevators and rudder. This complete three-axis control scheme was needed because the pilot had only limited control over the rotor. Only the front propeller was powered, so this aircraft could not hover, and could lose control at low speed. The vertical axis rotor spun freely; the faster the autogyro flew, the faster the rotor would spin and the greater lift it produced.

A replica of the Cierva C.6 was built to be shown in Murcia pavilion in Seville Expo '92 World's Fair. That replica can be now be seen in Museo del Aire, Cuatro Vientos, Madrid, Spain.

Variants

Cierva C.6

Prototype.

Cierva C.6A

Powered by a 82-kW (110-hp) Le Rhone 9Ja rotary piston engine.

Cierva C.6B

Cierva C.6C

Powered by a 97-kW (130-hp) Clerget rotary piston engine. Built in the United Kingdom as **Avro Type 574**.

Cierva C.6D

Powered by a 97-kW (130-hp) Clerget rotary piston engine. Built in the United Kingdom as the **Avro Type 575**.

Specifications (C.6)

General characteristics

- **Crew:** One or two
- **Length:** 9 m (29 ft 6 in)
- **Rotor diameter:** 10 m (32 ft 9½ ft)
- **Height:** ()
- **Max takeoff weight:** 900 kg (1,984 lb)
- **Powerplant:** 1× Le Rhône 9J 9-cylinder rotary engine with a two-bladed propeller, 82 kW (110 hp)

Performance

- **Maximum speed:** 100 km/h (54 knots, 62 mph)

Rotorsport UK MT-03

Rotorsport UK MT-03

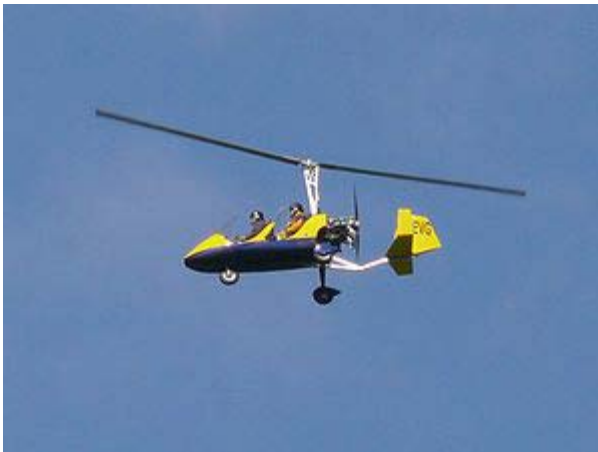

Role	Autogyro
National origin	United Kingdom
Manufacturer	Rotorsport UK
Developed from	AutoGyro MT-03
Variants	BAE Ampersand

The **Rotorsport UK MT-03** is a two-seater autogyro to British Civil Airworthiness Requirements CAP643 Section T. New build-aircraft based on the AutoGyro MT-03 design are imported from Germany and completed to British regulations by Rotorsport UK Limited in the United Kingdom.

The autogyro has two tandem seats and is powered by a 100 hp (75 kW) Rotax 912 ULS although optionally a 115 hp (86 kW) Rotax 914 UL Turbo can be fitted.

An unmanned reconnaissance technology demonstrator variant has been proposed as the BAE Ampersand.

Specifications (Rotax 912)

General characteristics

- **Crew:** 2
- **Length:** 4.95 m (16 ft 3 in)
- **Width:** 1.82 m (6 ft 0 in)
- **Height:** 2.7 m (8 ft 10 in)
- **Empty weight:** 250 kg (551 lb)
- **Max takeoff weight:** 450 kg (992 lb)
- **Powerplant:** 1 × Rotax 912 ULS four-stroke piston engine, 75 kW (100 hp)
- **Main rotor diameter:** 8.4 m (27 ft 7 in)
- **Propellers:** 3-bladed HTC 3 blade ground adjustable, composite, 1.72 m (5 ft 8 in) diameter

Performance

- **Never exceed speed:** 160 km/h; 87 kn (100 mph) Vne
- **Rate of climb:** 5.6 m/s (1,100 ft/min)

Chapter- 7

Gyrodyne



Fairey FB-1 Gyrodyne developed by Dr. Bennett

A **Gyrodyne** is a rotorcraft with a rotor system that is normally driven by its engine for takeoff and landing—hovering like a helicopter and has either one or two propellers mounted on wingtips, for propulsion and for torque correction. Dr. James Allan Jamieson Bennett conceived the gyrodyne while serving as Chief Engineer at Cierva Autogiro Company, Ltd. The gyrodyne was envisioned an intermediate type of rotorcraft, its rotor operating parallel to the flightpath to minimize axial flow with one or more propellers providing propulsion.

There is controversy over the correct usage of the term *gyrodyne* stemming from the difference between the description in Bennett's patent, the use of the term as a trademark by the Gyrodyne Company of America, the Federal Aviation Administration (FAA) classification of rotorcraft, and the terms **compound helicopter** and **compound gyroplane** frequently used to describe similar aircraft. In recent years, a related concept has been promoted under the name **heliplane**. Originally used to market gyroplanes built by two different companies, the term has been adopted to describe a Defense Advanced Research Projects Agency (DARPA) program to develop advances in rotorcraft technology with the goal of overcoming the current limitations of helicopters in both speed and payload.

History

In Britain, Dr. James Allan Jamieson Bennett, Chief Engineer of the Cierva Autogiro Company, in 1936 conceived an intermediate type of rotorcraft, which he named

"gyrodyne" and which was tendered to the British Government in response to an Air Ministry specification. In 1939, Bennett was issued a patent from the UK Intellectual Property Office, assigned to the Cierva Autogiro Company. On 23 August 1940, the Autogiro Company of America, licensees of the Cierva Autogiro Company, Ltd., filed a corresponding patent application in the United States. On 27 April 1943, Patent# 2,317,340 was issued, assigned to the Autogiro Company of America. The patents describe a gyrodyne as:

a rotary wing aircraft intermediate in type, hereinafter referred to as "gyrodyne", between a rotaplane (with the rotor free for autorotation and an upward total axial flow through the rotor disc), on the one hand, and a pure helicopter (with the rotor driven, and a downward total axial flow through the rotor disc), on the other hand, that is with a mean axial flow through the rotor disc substantially zero at high forward speed.

Bennett's concept described a shaft-driven rotor, with anti-torque and propulsion for translational flight provided by one or more propellers mounted on short or stub wings. With thrust being provided by the propellers at cruise speeds, power would be provided to the rotor only to overcome the profile drag of the rotor, operating in a more efficient manner than the freewheeling rotor of an autogyro in autorotation. Bennett described this flight regime of the gyrodyne as an "intermediate state", requiring power to be supplied to both the rotor and the propulsion system.

Early development

The Cierva Autogiro Company, Ltd., C.41 gyrodyne pre-WW2 design study was updated and built by Fairey Aviation as the FB-1 Gyrodyne commencing in 1945. Fairey's development efforts were initially led by Bennett, followed by his successor Dr. George S. Hislop. George B.L. Ellis and Frederick L. Hodgess, engineers from the pre-WW2 Cierva Autogiro Company, Ltd., joined Bennett at Fairey Aviation. The first Fairey Gyrodyne prototype crashed during a test flight, killing the crew. The second Gyrodyne prototype was rebuilt as the Jet Gyrodyne and used to develop a pressure-jet rotor drive system later for the Rotodyne transport compound gyroplane. At the tip of each stub wing were rearward-facing propellers which provided both yaw control and propulsion in forward flight. The Jet Gyrodyne flew in 1954, and made a true transition from vertical to horizontal flight in March 1955.

This led to the prototype Fairey Rotodyne, which was developed to combine the efficiency of an fixed-wing aircraft at cruise with the VTOL capability of a helicopter to provide short haul airliner service from city centres to airports. It had short wings that carried turboprop engines for forward propulsion and up to 40% of the aircraft's weight in forward flight. The rotor was driven by tip-jets for take-off and landing and translational flight up to 80 mph. Despite considerable commercial and military interest worldwide in the prototype Type Y Rotodyne for air transport, Fairey decided to develop a larger and more powerful Type Z Rotodyne which, together with withdrawal of British Government support in 1962, resulted in the termination of the project. With the end of the Fairey

Aviation programs, gyrodyne development came to a halt, although several similar concepts continued to be developed.

Similar developments

In 1954, the McDonnell XV-1 was developed as a rotorcraft with tip jets to provide vertical take off capability. The aircraft also had wings and a propeller mounted on the rear of the fuselage between twin tailbooms with two small anti-torque rotors mounted at the end. Two prototypes were built and tested, with the second XV-1 became the world's first rotorcraft to exceed 200 mph in level flight on 10 October 1956. The XV-1 project was terminated in 1957.

Compound autogyro

In 1998, Carter Aviation Technologies successfully flew its technology demonstrator aircraft. The aircraft is a compound autogyro with a high-inertia rotor and wings optimized for high-speed flight. In 2005, the aircraft demonstrated flight at $\mu-1$, with the rotor tip spinning at a speed equal to the aircraft's forward airspeed, without any vibration or control issues occurring. The high-inertia rotor allows the aircraft to hover for a brief moment during landing, even though the rotor is unpowered, and a prerotating gearbox allows the rotor to be accelerated for an autogyro-style jump takeoff.

Heliplane

In 1954, Kayaba built an aircraft named the Heliplane. The Heliplane was a Cessna 170 with wings reduced to stubs sufficient to carry the undercarriage and a rotor powered by tip ram-jets.

DARPA is funding a project under the "Heliplane" name to develop the gyrodyne concept. Aircraft developed for the project will use a rotor for take-off and landing vertically, and hovering, together with substantial wings to provide most of the required lift at cruise, combining the large cargo capacity, fuel efficiency, and high cruise speed of fixed-wing aircraft with the hovering capabilities of a helicopter. The project is "...a multi-year \$40-million, four-phase program. Groen Brothers is working on phase one of that program, a 15-month effort...(it) combines the "gyroplane" ..with a fixed-wing business jet. The team is using the A700, in the very-light-jet class, which was developed by Adam Aircraft Industries."

Trademark

"Gyrodyne" was granted as a trademark to the Gyrodyne Company of America in 1950. The company was not involved in gyrodyne development, but instead produced a turbine-engined, remotely-piloted drone helicopter, with coaxial rotors, for the United States Navy, designated as the QH-50 DASH.

Chapter- 8

Specific Types of Gyrodyne

Fairey FB-1 Gyrodyne

FB-1 Gyrodyne



The Fairey FB-1 Gyrodyne prototype in test

Role	Gyrodyne
National origin	United Kingdom
Manufacturer	Fairey
Designed by	Dr. J.A.J. Bennett
First flight	4 December 1947
Retired	Cancelled 1949
Number built	2
Developed from	Cierva C.39 Gyrodyne 1936 design study
Variants	Jet Gyrodyne

The **Fairey FB-1 Gyrodyne** was an experimental British rotorcraft that used single lifting rotor and a tractor propeller mounted on the tip of the starboard stub wing to provide both propulsion and anti-torque reaction.

Design and development

In April 1946, Fairey announced a private-venture project for a rotary-wing aircraft, to be built to a design originated by Dr. J.A.J. Bennett when he was Chief Technical Officer of the Cierva Autogiro Company, Ltd., during the period 1936-1939. The Gyrodyne,

designated C.41 by the Cierva Autogiro Company, was in 1938 successfully tendered to the Royal Navy in response to Specification S.22/38 for a naval helicopter. Though preliminary work started on the project, it was abandoned with the outbreak of the Second World War, and G & J Weir, Ltd., the financiers of the Cierva Autogiro Company, declined to undertake further development in addition to their successful experiments with the W.5 and W.6 lateral twin-rotor helicopters. After the Second World War, the Cierva Autogiro Company was engaged with the development of the Cierva W.9 "Drainpipe" and the W.11 Air Horse helicopters under the direction of Cyril Pullin, and Bennett joined Fairey in late 1945 as head of the newly established rotary wing aircraft division.

The Gyrodyne was a compact, streamlined rotorcraft weighing just over 4,410 lb (2,000 kg) and powered by a 525 hp (390 kW) Alvis Leonides radial engine, the power from which could be transmitted in variable ratios to the fixed-shaft/swashplate-actuated tilting hub-controlled rotor and the wing tip mounted propeller. The Gyrodyne possessed the hovering capability of a helicopter, while its propeller provided the necessary thrust for forward flight to enable its rotor, driven at low torque in cruise flight, to operate at low collective pitch with the tip-path plane parallel to the flight path to minimise vibration at high airspeed.

A government contract to Specification E.4/46 was awarded for two prototypes with the first Fairey Gyrodyne exhibited as an almost complete airframe at White Waltham on 7 December 1946.

Testing and evaluation

On 4 December 1947, the first of the two prototypes took off from White Waltham Airport, and continued to build up flying time until March 1948 when it was dismantled for a thorough examination. The second prototype, basically similar to the first but with more comfortable interior furnishings befitting its role as a passenger demonstrator, was flying by the time of the next SBAC Display, in September 1948, at Farnborough. The first prototype was reassembled and, following further test flying, took part in an attempt to set a new world helicopter speed record in a straight line.

On 28 June 1948, flown by test pilot Basil Arkell, the Gyrodyne made two flights in each direction over a 2 mi (3 km) course at White Waltham, achieving 124 mph (200 km/h), enough to secure the record. An attempt was to be made in April 1949 to set a 62 mi (100 km) closed-circuit record, but two days before the date selected a poorly machined flapping link in the rotor hub failed during flight and resulted in the crash of the aircraft at Ufton, near Reading, killing the pilot, Foster H. Dixon and observer, Derek Garraway.

The Gyrodyne had been selected for use by the British Army for use in Malaya, beating both the Westland/Sikorsky S.51 Dragonfly and Bristol 171 Sycamore, with an order for six approved by the Treasury at the time of the accident. Though the Gyrodyne's projected performance was significantly better than that of the Dragonfly, and was expected to be in service earlier than the Sycamore, the crash of the first prototype

delayed the development programme and the Army, having no other choice, acquired three S.51 Dragonflies, followed by Sycamores at a later date.

The second Gyrodyne was grounded during the accident investigation which determined flapping hinge retaining nut failure due to poor machining as the cause. The extensively modified second prototype, renamed Jet Gyrodyne, flew in January 1954. Though retaining the name "Gyrodyne", the Jet Gyrodyne was a compound gyroplane, and did not operate on the same principle as the original aircraft. It had a two-blade rotor manually controlled with cyclic and collective pitch mechanisms that acted directly on each rotor blade; and was driven by tip jets fed with air from two compressors driven by the Alvis Leonides radial engine. Pusher propellers, one mounted at the tip of each stub wing, provided yaw control through differential collective pitch, and thrust for forward flight. The Jet Gyrodyne was constructed to provide rotor drive and operational data for the Fairey Rotodyne compound gyroplane.

The Jet Gyrodyne is on display at the Museum of Berkshire Aviation, Woodley, Reading.

Specifications (Fairey FB-1 Gyrodyne)

General characteristics

- **Crew:** One
- **Capacity:** Four to five passengers
- **Length:** 19 ft 2 in (5.84 m)
- **Rotor diameter:** 52 ft 0 in (15.85 m)
- **Height:** 10 ft 1 in (3.07 m)
- **Airfoil:** NACA 23018
- **Empty weight:** 3,592 lb (1,633 kg)
- **Max takeoff weight:** 4,800 lb (2,177 kg)
- **Powerplant:** 1× Alvis Leonides 9-cylinder radial piston engine, 525 hp (391 kW)

Performance

- **Maximum speed:** 140 mph (122 kn, 225 km/h)

Fairey Jet Gyrodyne

Fairey Jet Gyrodyne



Role	Gyrodyne
National origin	United Kingdom
Manufacturer	Fairey Aviation
First flight	January 1954 (free flight) 1 March 1955 (transition flight)
Retired	1961
Number built	1
Developed from	Fairey Gyrodyne
Variants	Fairey Rotodyne

The **Fairey Jet Gyrodyne** was a British experimental compound autogyro built by the Fairey Aviation Company that incorporated helicopter, gyrodyne and autogyro characteristics. The Jet Gyrodyne was the subject of a Ministry of Supply (MoS) research contract to gather data for the follow-up design, the Rotodyne.

Design and development

The Jet Gyrodyne was a modification of the second prototype FB-1 Gyrodyne aircraft registered *G-AJJP*. The Jet Gyrodyne was built specifically to develop the pressure-jet rotor drive system and operational procedures used on the later Rotodyne.

The appearance of the Jet Gyrodyne utilised the fuselage, undercarriage and engine of the FB-1 Gyrodyne. The Alvis Leonides nine-cylinder radial engine was situated in the middle of the fuselage and drove a pusher propeller at the tip of each stub wing and two Rolls-Royce Merlin engine superchargers. The original three-blade tilting hub rotor system was replaced by a two-blade rotor controlled with cyclic and collective pitch controls. An empennage provided the necessary stabilization about the pitch and yaw axes.

For takeoff, landing, and low-speed flight, the rotor was driven by air delivered by the superchargers and burnt with fuel in blade-tip mounted pressure-jets. This zero-torque rotor drive did not require a compensating anti-torque system, though the collective pitch of the wingtip-mounted propellers was controlled by the rudder pedals to provide yaw control. As airspeed was gained, the rotor drive system was shut down, allowing the rotor to autorotate while the propellers provided the necessary thrust. For low-speed flight and landing, the rotor drive system was restarted to provide hovering capability.

Operational history

Tethered flights at White Waltham were followed by the first free flight in January 1954, but a full transition from helicopter to autogyro flight was not achieved until March 1955, piloted by John N. Dennis. System proving continued and by September 1956, 190 transitions and 140 autorotative landings had been completed. Development of inflight rotor drive restart procedure resulted in several power-off autorotational landings until the method was perfected. The Jet Gyrodyne was underpowered and could carry sufficient fuel for only 15 minutes of flight; on occasion external fuel tanks were carried to increase endurance.

The Jet Gyrodyne was retired once ground testing of the Rotodyne rotor drive system commenced.

Aircraft on display

Although scheduled for scrapping in 1961, the Jet Gyrodyne (serial number *XD759* later *XJ389*) survived and today is displayed at the Museum of Berkshire Aviation, on loan from the RAF Museum collection.

Specifications (Jet Gyrodyne)

General characteristics

- **Length:** 25 ft (7.6 m)
- **Rotor diameter:** 51 ft 9 in (15.8 m)
- **Height:** 10 ft 2 in (3.10 m)
- **Empty weight:** 3,600 lb (1,600 kg)
- **Loaded weight:** 4,800 lb (2,200 kg)
- **Powerplant:**
 - 2× wingtip compressed air/fuel burning, () each
 - 1× Alvis Leonides 9-cylinder radial engine, ()
 - **Propellers:** 3-bladed propeller, 2 per engine

Performance

- **Maximum speed:** 140 mph (120 kn, 224 km/h)

Fairey Rotodyne

Rotodyne



The Fairey Rotodyne

Role	Compound gyroplane
National origin	United Kingdom
Manufacturer	Fairey Aviation
First flight	6 November 1957
Status	Cancelled 1962
Number built	1
Developed from	Fairey Jet Gyrodyne

The **Fairey Rotodyne** was a 1950s British compound gyroplane designed and built by Fairey Aviation and intended for commercial and military applications. A development of the earlier Gyrodyne which had established a world helicopter speed record, the Rotodyne featured a tip-jet-powered rotor that burned a mixture of fuel and compressed air bled from two wing-mounted Napier Eland turboprops. The rotor was driven for vertical takeoffs, landings and hovering, and low-speed translational flight, and autorotated during cruise flight with all engine power applied to two propellers. Although promising in concept and entirely successful in trials, the Rotodyne program was eventually cancelled when a combination of politics and the lack of commercial orders doomed the project.

Design and development

Fairey developed the Fairey FB-1 Gyrodyne, a unique aircraft in its own right that defined a third type of rotorcraft, including autogyro and helicopter. Having little in common with the later Rotodyne, it was characterised by its inventor, Dr. J.A.J. Bennett, formerly Chief Technical Officer of the pre-Second World War Cierva Autogiro Company as an intermediate aircraft designed to combine the safety and simplicity of the autogyro with hovering performance. Its rotor was driven in all phases of flight with collective pitch being an automatic function of shaft torque, with a side-mounted propeller providing both thrust for forward flight and rotor torque correction. The FB-1 set a world airspeed record in 1948, but a fatal accident due to poor machining of a rotor blade flapping link retaining nut terminated development of the pure gyrodyne. The second FB-1 was modified to investigate a tip-jet driven rotor with propulsion provided by propellers mounted at the tip of each stub wing. This was renamed the Jet Gyrodyne, which despite its name, was a compound autogyro.

Fairey put forward their various designs for the proposed **BEA Bus**, which were revised over the years, and received government funding. However, getting access to engines proved to be difficult, with first Rolls-Royce then Armstrong Siddeley claiming lack of resources. The Ministry of Supply contracted in 1953 for the building of the prototype (serial number *XE521*).

The Rotodyne had a large, four-blade rotor and two Napier Eland N.E.L.3 turboprops, one mounted under each of the fixed wings. For takeoff and landing, the rotor was driven by tip-jets, powered by compressors driven through a clutch by the main engines, and the compressed air produced was mixed with fuel and burned. As a torqueless rotor system, no anti-torque correction system was required, though propeller pitch was controlled by the rudder pedals for low-speed yaw control. The propellers provided thrust for translational flight while the rotor autorotated. The cockpit controls included a cyclic and collective pitch lever, as in a conventional helicopter.

While the prototype was being built, funding for the program reached a crisis. Cuts in defence spending led the Ministry of Defence to withdraw support, pushing the burden of the costs onto any possible civilian customer. The Government agreed to continued funding only if, among other qualifications, Fairey and Napier (through their parent English Electric) contributed to development costs of the Rotodyne and the Eland engine respectively.

Testing and evaluation



The Fairey Rotodyne prototype circa 1959

Although J.A.J. Bennett had left Fairey to join Hiller Helicopters in California, the prototype, its development assumed by Dr. George S. Hislop, made its first flight on 6 November 1957 piloted by Chief Helicopter Test Pilot Squadron Leader W. Ron Gellatly and Assistant Chief Helicopter Test Pilot Lieutenant Commander John G.P. Morton as Second Pilot.

The first successful transition from vertical to horizontal and back to vertical flight was achieved on 10 April 1958. The Rotodyne performed to expectations and set a world speed record in the convertiplane category, at 190.9 mph (307.2 km/h) on 5 January 1959, over a 60 mi (100 km) closed circuit. As well as being fast, the craft had a safety feature: it could hover with one engine shut down with its propeller feathered, and the prototype demonstrated several landings as an autogyro. The prototype was demonstrated several times at the Farnborough and Paris air shows, regularly amazing onlookers. The Rotodyne's tip drive and unloaded rotor made its performance far better when compared to pure helicopters and other forms of "convertiplanes." The aircraft could be flown at 175 kn (324 km/h) and pulled into a steep climbing turn without demonstrating any adverse handling characteristics.

Throughout the world, interest was growing in the prospect of direct city-to-city transport. The market for the Rotodyne was that of a medium-haul "flying bus": it would take off vertically from an inner-city heliport, with all lift coming from the tip-jet driven

rotor, and then would increase airspeed, eventually with all power from the engines being transferred to the propellers with the rotor autorotating. In this mode, the collective pitch, and hence drag, of the rotor could be reduced, as the wings would be taking as much as half of the craft's weight. The Rotodyne would then cruise at speeds of about 150 kn (280 km/h) to another city (e.g. London to Paris) where the rotor tip-jet system would be restarted for landing vertically in the city centre. When the Rotodyne landed and the rotor stopped moving, its blades drooped downward from the hub. To avoid striking the vertical stabilizers on start-up, the tips of these fins were angled down to the horizontal. They were raised once the rotor had spun up.

British European Airways (BEA) announced that it was interested in the purchase of six aircraft, with a possibility of up to 20. The Royal Air Force ordered 12 military transport versions. New York Airways signed a letter of intent for the purchase of five with an option on more albeit with qualifications. The U.S. Army was interested in buying 200 of the Type Y Rotodyne to be manufactured by Fairey's US licensee, Kaman Helicopters in Bloomfield, Connecticut. Government funding was secured again on the proviso that firm orders would be gained from BEA. The civilian orders were dependent on the noise issues being satisfactorily met.

Cancellation

In 1959, the British Government, seeking to cut costs, decreed that the number of aircraft firms be lowered and set forth their expectations for mergers in airframe and aero-engine companies. By delaying or withholding access to defence contracts the British firms could be forced into mergers. Fairey Aviation, then the helicopter division of Bristol, and Saunders-Roe were incorporated with Westland. The larger Rotodyne design could be developed to take 57 to 75 passengers which with the Rolls-Royce Tyne turboprops (5,250 shp/3,910 kW) would have a cruising speed of 200 kn (370 km/h). It would be able to carry nearly 8 tons (7 tonnes) of freight and British Army vehicles would fit into its fuselage. Government funding of some £5 million was promised. The expected order from the RAF did not appear - they had no particular interest in the design with the issue of nuclear deterrence to the fore at the time. The Tyne engines were starting to appear underpowered for the larger design. Rolls-Royce were told that they would have to fund the engine development themselves.

However, the end came when the interest shown by BEA did not provide an order and a request for an order by the military was turned down. The funding for the Rotodyne was cut in early 1962. The corporate management at Westland decided that further Rotodyne development towards production status was not worth the investment required. After the program was terminated, the Rotodyne, which was, after all, government property, was dismantled and largely destroyed in the same way as the Bristol Brabazon.

Analysis

The one great criticism of the Rotodyne was the noise the tip jets made, however, the jets were only run at full power for a matter of minutes during departure and landing and

indeed, the test pilot Ron Gelattly made two flights over central London, and several landings and departures at Battersea Heliport with no complaints being registered. There was also a noise-reduction program in process which had managed to get the noise level down to the desired level of 96 dB from 600 ft (180 m) away, less than the noise made by a London Underground train, and at the time of cancellation, silencers were in the pipeline which would have reduced the noise even further. In the end though it was funding and not noise that killed the Rotodyne.

It is only relatively recently that interest has been re-established in direct city-to-city transport, with aircraft such as the Bell/Augusta BA609 and the Carter Copter. Groen Brothers Aviation are developing techniques for converting proven aeroplane designs into gyrodynes.

Specifications (Rotodyne "Y")

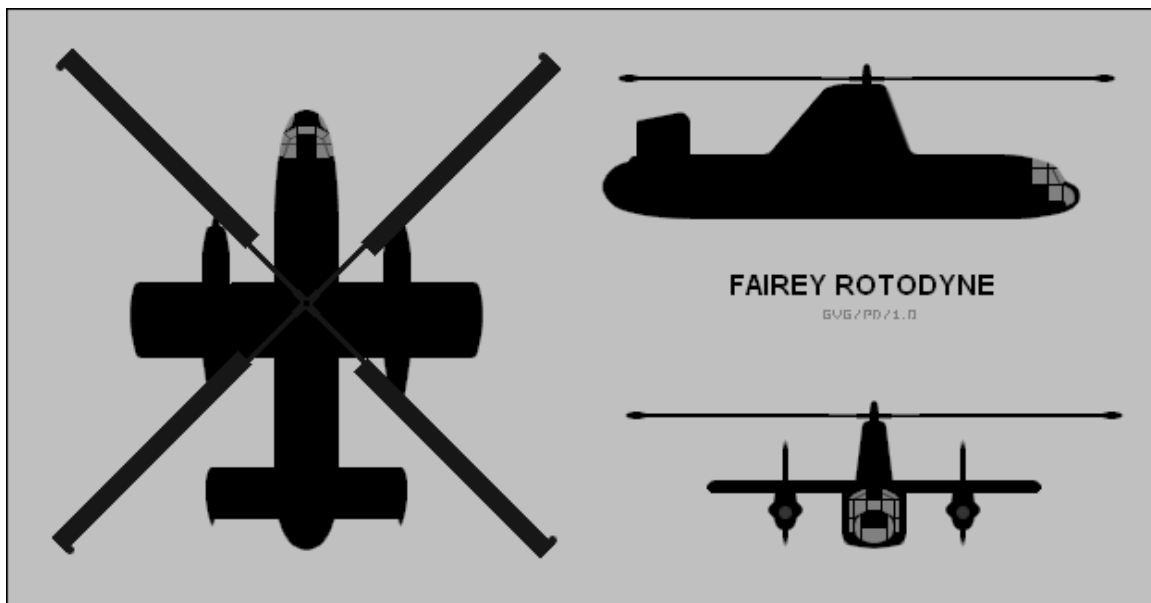

General characteristics

- **Crew:** 2
- **Capacity:** 48 passengers
- **Length:** 58 ft 8 in (17.9 m)
- **Rotor diameter:** 90 ft 0 in (27.4 m)
- **Height:** 22 ft 2 in (6.76 m)
- **Disc area:** 6,360 ft² (591 m²)
- **Loaded weight:** 33,000 lb (15,000 kg)
- **Max takeoff weight:** 38,000 lb (17,000 kg)
- **Powerplant:**
 - 4× rotor tip jet burning compressed air/fuel, 4453 N () each
 - 2× Napier Eland turboprops, 2,800 hp (2,100 kW) each

Performance

- **Maximum speed:** 213 mph (343 km/h)
- **Range:** 520 mi (830 km)
- **Disc loading:** 5.2 lb/ft² (25 kg/m²)
- **Power/mass (prop):** 0.17 hp/lb (280 W/kg)