

# Heating, Ventilating, and Air Conditioning Technologies

**Gwenn Camara**



First Edition, 2012

ISBN 978-81-323-3069-1

© All rights reserved.

*Published by:*

**Research World**

4735/22 Prakashdeep Bldg,

Ansari Road, Darya Ganj,

Delhi - 110002

Email: [info@wtbooks.com](mailto:info@wtbooks.com)

# Table of Contents

Chapter 1 - HVAC

Chapter 2 - Building Automation

Chapter 3 - Central Heating

Chapter 4 - Heat Exchanger

Chapter 5 - Blower Door

Chapter 6 - Chilled Beam

Chapter 7 - Chiller

Chapter 8 - Air Conditioning

Chapter 9 - Ventilation (Architecture)

Chapter 10 - Air Handler

Chapter 11 - HVAC Control System and Duct (HVAC)

Glossary

## Chapter 1

# HVAC

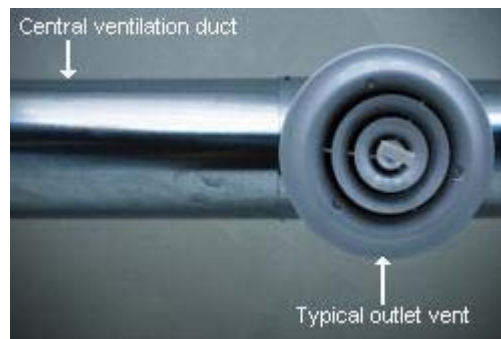

HVAC systems use ventilation air ducts installed throughout a building that supply conditioned air to a room through rectangular or round outlet vents, called diffusers; and ducts that remove air through return-air grilles

**HVAC** (Heating, Ventilating, and Air Conditioning) refers to technology of indoor or automotive environmental comfort. HVAC system design is a major subdiscipline of mechanical engineering, based on the principles of thermodynamics, fluid mechanics, and heat transfer. Refrigeration is sometimes added to the field's abbreviation as HVAC&R or HVACR, or ventilating is dropped as in HACR (such as the designation of HACR-rated circuit breakers).

HVAC is important in the design of medium to large industrial and office buildings such as skyscrapers and in marine environments such as aquariums, where safe and healthy building conditions are regulated with temperature and humidity, as well as "fresh air" from outdoors.

## Background

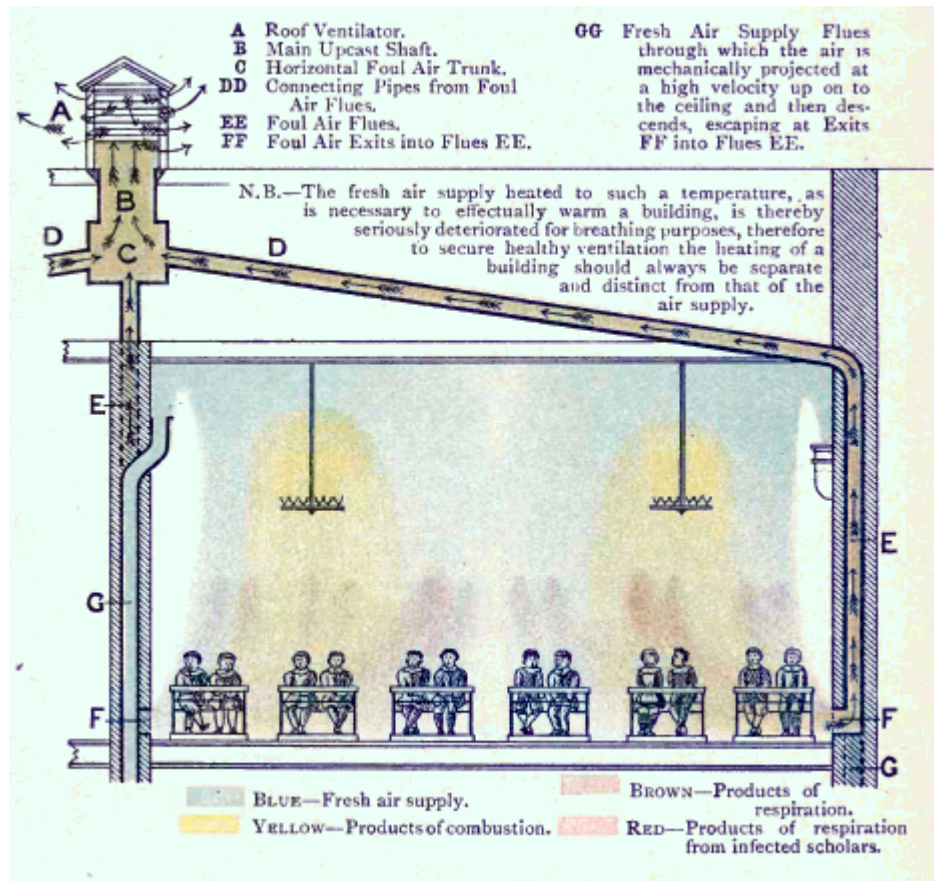

Ventilation (architecture) on the downdraught system, by impulsion, or the 'plenum' principle, applied to schoolrooms (1899)

Heating, ventilating, and air conditioning is based on inventions and discoveries made by Nikolay Lvov, Michael Faraday, Willis Carrier, Reuben Trane, James Joule, William Rankine, Sadi Carnot, and many others.

The invention of the components of HVAC systems went hand-in-hand with the industrial revolution, and new methods of modernization, higher efficiency, and system control are constantly introduced by companies and inventors all over the world. The three central functions of heating, ventilating, and air-conditioning are interrelated, providing thermal comfort, acceptable indoor air quality, within reasonable installation, operation, and maintenance costs. HVAC systems can provide ventilation, reduce air infiltration, and maintain pressure relationships between spaces. How air is delivered to, and removed from spaces is known as room air distribution.

In modern buildings the design, installation, and control systems of these functions are integrated into one or more HVAC systems. For very small buildings, contractors normally "size" and select HVAC systems and equipment. For larger buildings, building services designers and engineers, such as mechanical, architectural, or building services

engineers analyze, design, and specify the HVAC systems, and specialty mechanical contractors build and commission them. Building permits and code-compliance inspections of the installations are normally required for all sizes of buildings.

The HVAC industry is a worldwide enterprise, with career opportunities including operation and maintenance, system design and construction, equipment manufacturing and sales, and in education and research. The HVAC industry had been historically regulated by the manufacturers of HVAC equipment, but Regulating and Standards organizations such as HARDI, ASHRAE, SMACNA, ACCA, Uniform Mechanical Code, International Mechanical Code, and AMCA have been established to support the industry and encourage high standards and achievement.

Design of the HVAC system.

The starting point in carrying out a heat estimate both for cooling and heating will depends on the ambient and inside conditions specified. However before taking up the heat load calculation, it is necessary to work out the fresh air requirement for each area in details, as pressurization is an important requirement.

## ***Heating***



Central heating unit

There are many different types of standard heating systems. Central heating is often used in cold climates to heat private houses and public buildings. Such a system contains a boiler, furnace, or heat pump to heat water, steam, or air, all in a central location such as a furnace room in a home or a mechanical room in a large building. The use of water as the heat transfer medium is known as hydronics. The system also contains either ductwork, for forced air systems, or piping to distribute a heated fluid and radiators to transfer this heat to the air. The term *radiator* in this context is misleading since most heat transfer from the heat exchanger is by convection, not radiation. The radiators may be mounted on walls or buried in the floor to give under-floor heat.

In boiler fed or radiant heating systems, all but the simplest systems have a pump to circulate the water and ensure an equal supply of heat to all the radiators. The heated water can also be fed through another (secondary) heat exchanger inside a storage cylinder to provide hot running water.

Forced air systems send heated air through ductwork. During warm weather the same ductwork can be used for air conditioning. The forced air can also be filtered or put through air cleaners.

Heating can also be provided from electric, or resistance heating using a filament that becomes hot when electric current is caused to pass through it. This type of heat can be found in electric baseboard heaters, portable electric heaters, and as backup or supplemental heating for heat pump (or reverse heating) system.

The heating elements (radiators or vents) should be located in the coldest part of the room, typically next to the windows to minimize condensation and offset the convective air current formed in the room due to the air next to the window becoming negatively buoyant due to the cold glass. Devices that direct vents away from windows to prevent "wasted" heat defeat this design intent. Cold air drafts can contribute significantly to subjectively feeling colder than the average room temperature. Therefore, it is important to control the air leaks from outside in addition to proper design of the **heating system**.

The invention of central heating is often credited to the ancient Romans, who installed a system of air ducts called a hypocaust in the walls and floors of public baths and private villas.

## Ventilating

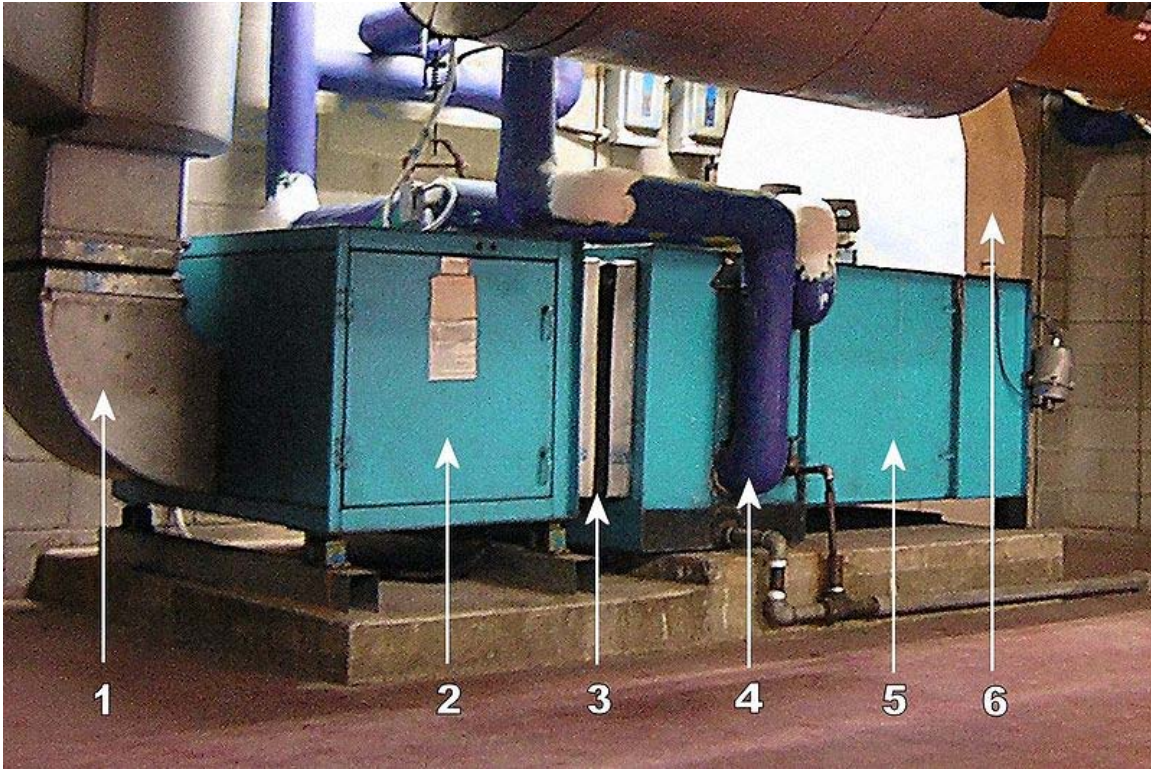

An air handling unit is used for the heating and cooling of air in a central location.

Ventilating is the process of "changing" or replacing air in any space to control temperature or remove moisture, odors, smoke, heat, dust, airborne bacteria, carbon dioxide, and to replenish oxygen. Ventilation includes both the exchange of air to the outside as well as circulation of air within the building. It is one of the most important factors for maintaining acceptable indoor air quality in buildings. Methods for ventilating a building may be divided into *mechanical/forced* and *natural* types. Ventilation is used to remove unpleasant smells and excessive moisture, introduce outside air, to keep interior building air circulating, and to prevent stagnation of the interior air.

### **Mechanical or forced ventilation**

"Mechanical" or "forced" ventilation is provided by an air handler and used to control indoor air quality. Excess humidity, odors, and contaminants can often be controlled via dilution or replacement with outside air. However, in humid climates much energy is required to remove excess moisture from ventilation air.

Kitchens and bathrooms typically have mechanical exhaust to control odors and sometimes humidity. Factors in the design of such systems include the flow rate (which is a function of the fan speed and exhaust vent size) and noise level. If ducting for the fans traverse unheated space (e.g., an attic), the ducting should be insulated as well to prevent

condensation on the ducting. Direct drive fans are available for many applications, and can reduce maintenance needs.

Ceiling fans and table/floor fans circulate air within a room for the purpose of reducing the perceived temperature because of evaporation of perspiration on the skin of the occupants. Because hot air rises, ceiling fans may be used to keep a room warmer in the winter by circulating the warm stratified air from the ceiling to the floor. Ceiling fans do not provide ventilation as defined as the introduction of outside air.

## **Natural ventilation**

Natural ventilation is the ventilation of a building with outside air without the use of a fan or other mechanical system. It can be achieved with openable windows or trickle vents when the spaces to ventilate are small and the architecture permits. In more complex systems warm air in the building can be allowed to rise and flow out upper openings to the outside (stack effect) thus forcing cool outside air to be drawn into the building naturally through openings in the lower areas. These systems use very little energy but care must be taken to ensure the occupants' comfort. In warm or humid months, in many climates, maintaining thermal comfort solely via natural ventilation may not be possible so conventional air conditioning systems are used as backups. Air-side economizers perform the same function as natural ventilation, but use mechanical systems' fans, ducts, dampers, and control systems to introduce and distribute cool outdoor air when appropriate.

## ***Air conditioning***

Air conditioning and refrigeration are provided through the removal of heat. The definition of cold is the absence of heat and all air conditioning systems work on this basic principle. Heat can be removed through the process of radiation, convection, and Heat cooling through a process called the refrigeration cycle. The conduction mediums such as water, air, ice, and chemicals are referred to as refrigerants.

An air conditioning system, or a standalone air conditioner, provides cooling, ventilation, and humidity control for all or part of a house or building.

The refrigerant cycle consists of four essential elements to create a cooling effect. The system refrigerant starts its cycle in a gaseous state. The compressor pumps the refrigerant gas up to a high pressure and temperature. From there it enters a heat exchanger (sometimes called a "condensing coil") where it loses energy (heat) to the outside. In the process the refrigerant condenses into a liquid. The liquid refrigerant is returned indoors to another heat exchanger ("evaporating coil"). A metering device allows the liquid to flow in at a low pressure at the proper rate. As the liquid refrigerant evaporates it absorbs energy (heat) from the inside air, returns to the compressor, and the cycle repeats. In the process, heat is absorbed from indoors, and transferred outdoors, resulting in cooling of the building.

Central, 'all-air' air conditioning systems are often installed in modern residences, offices, and public buildings, but are difficult to retrofit (install in a building that was not designed to receive it) because of the bulky air ducts required. A duct system must be carefully maintained to prevent the growth of pathogenic bacteria in the ducts. An alternative to large ducts to carry the needed air to heat or cool an area is the use of remote fan coils or split systems. These systems, although most often seen in residential applications, are gaining popularity in small commercial buildings. The evaporator coil is connected to a remote condenser unit using piping instead of ducts.

Dehumidification in an air conditioning system is provided by the evaporator. Since the evaporator operates at a temperature below dew point, moisture in the air condenses on the evaporator coil tubes. This moisture is collected at the bottom of the evaporator in a condensate pan and is removed by piping it to a central drain or onto the ground outside. A dehumidifier is an air-conditioner-like device that controls the humidity of a room or building. It is often employed in basements which have a higher relative humidity because of their lower temperature (and propensity for damp floors and walls). In food retailing establishments, large open chiller cabinets are highly effective at dehumidifying the internal air. Conversely, a humidifier increases the humidity of a building.

Air-conditioned buildings often have sealed windows, because open windows would disrupt the attempts of the HVAC system to maintain constant indoor air conditions.

All modern air conditioning systems, down to small "window" units, are equipped with internal air filters. These are generally of a light weight gauze-type element, and must be replaced as conditions warrant (some models may be washable). For example, a building in a high-dust environment, or a home with furry pets, will need to have the filters changed more often than buildings without these dirt loads. Failure to replace these filters as needed will contribute to a lower heat-exchange rate, resulting in wasted energy, shortened equipment life, and higher energy bills; also low air flow can result in "iced-up" or "iced-over" evaporator coils, and then there is no air flow at all. Additionally, very dirty or plugged filters can cause overheating during a heating cycle, and can possibly result in damage to the furnace unit or even fire.

It is important to keep in mind that because an air conditioner moves heat from the indoor (evaporator) coil to the outdoor (condenser) coil, the latter must be kept just as clean as the former. This means that, in addition to replacing the air filter at the evaporator coil, it is also necessary to regularly clean the condenser coil. Failure to keep the condenser clean will eventually result in harm to the compressor, because the condenser coil is responsible for discharging both the indoor heat (as picked up by the evaporator) plus the heat generated by the electric motor driving the compressor.

Outside, "fresh" air is generally drawn into the system by a vent into the evaporator section. Adjustment of the percentage of return air made up of fresh air can usually be adjusted by manipulating the opening of this vent.

## **Energy efficiency**

For the last 20 to 30 years, manufacturers of HVAC equipment have been making an effort to make the systems they manufacture more efficient. This was originally driven by rising energy costs, and has more recently been driven by increased awareness of environmental issues. In the USA, the EPA has also imposed tighter restrictions. There are several methods for making HVAC systems more efficient.

## **Heating energy**

Water heating is more efficient for heating buildings and was the standard many years ago. Today forced air systems can double for air conditioning and are more popular.

A couple of benefits of forced air systems, which are now widely applied in churches, schools and high-end residences, are 1) better air conditioned effect 2) up to 15-20% energy saving, and 3) evenly conditioned effect. A drawback is the installation cost, which might be slightly higher than traditional HVAC system.

Energy efficiency can be improved even more in central heating systems by introducing zoned heating. This allows a more granular application of heat, similar to non-central heating systems. Zones are controlled by multiple thermostats. In water heating systems the thermostats control zone valves, and in forced air systems they control zone dampers inside the vents which selectively block the flow of air. In this case, the control system is very critical to maintain a proper temperature.

## **Geothermal Heat Pump**

Geothermal heat pumps are similar to ordinary heat pumps, but instead of using heat found in outside air, they rely on the stable, even heat of the earth to provide heating, air conditioning and, in most cases, hot water. From Montana's  $-70^{\circ}\text{F}$  ( $-57^{\circ}\text{C}$ ) temperature, to the highest temperature ever recorded in the U.S.— $134^{\circ}\text{F}$  ( $56.7^{\circ}\text{C}$ ) in Death Valley, California, in 1913—many parts of the country experience seasonal temperature extremes. A few feet below the earth's surface, however, the ground remains at a relatively constant temperature. Although the temperatures vary according to latitude, at 6 feet (1.83 m) underground, temperatures range from  $45$  to  $75^{\circ}\text{F}$  ( $7.2$  to  $23.9^{\circ}\text{C}$ ).

While they may be more costly to install initially than regular heat pumps, they can produce markedly lower energy bills—30 percent to 40 percent lower, according to estimates from the U.S. Environmental Protection Agency.

## **Ventilation energy recovery**

Energy recovery systems sometimes utilize heat recovery ventilation or energy recovery ventilation systems that employ heat exchangers or enthalpy wheels to recover sensible or latent heat from exhausted air. This is done by transfer of energy to the incoming outside fresh air.

## Air conditioning energy

The performance of vapor compression refrigeration cycles is limited by thermodynamics. These air conditioning and heat pump devices *move* heat rather than convert it from one form to another, so *thermal efficiencies* do not appropriately describe the performance of these devices. The **Coefficient-of-Performance (COP)** measures performance, but this dimensionless measure has not been adopted, but rather the **Energy Efficiency Ratio (EER)**. EER is the Energy Efficiency Ratio based on a 35 °C (95 °F) outdoor temperature. To more accurately describe the performance of air conditioning equipment over a typical cooling season a modified version of the EER is used, and is the **Seasonal Energy Efficiency Ratio (SEER)**. SEER ratings are based on seasonal temperature averages instead of a constant 35 °C outdoor temperature. The current industry minimum SEER rating is 13 SEER. The SEER article describes it further, and presents some economic comparisons using this useful performance measure.

Engineers have pointed out some areas where efficiency of the existing hardware could be improved. For example, the fan blades used to move the air are usually stamped from sheet metal, an economical method of manufacture, but as a result they are not aerodynamically efficient. A well-designed blade could reduce electrical power required to move the air by a third.

- Chilled beam
- Circulator pump
- Cooling tower
- Damper (flow)
- Dedicated outdoor air system
- Diffuser
- Displacement Ventilation
- Duct
- Economizer
- Evaporative cooler
- Fan coil unit
- Fan (mechanical)
- Heater
- Heat exchanger, including 'coils'
- Heat Pump
- Heat recovery ventilator
- Humidifier / Dehumidifier
- HVAC control system
- Piping
- Valve
- Variable air volume
- Variable-frequency drive, for fine control of pumps
- Underfloor air distribution

## HVAC industry and standards

### North America

#### USA

In the United States, HVAC engineers generally are members of the American Society of Heating, Refrigerating, and Air-Conditioning Engineers (ASHRAE). ASHRAE is an international technical society for all individuals and organizations interested in HVAC. The Society, organized into Regions, Chapters, and Student Branches, allows exchange of HVAC knowledge and experiences for the benefit of the field's practitioners and the

public. ASHRAE provides many opportunities to participate in the development of new knowledge via, for example, research and its many Technical Committees. These committees meet typically twice per year at the ASHRAE Annual and Winter Meetings. A popular product show, the AHR Expo, is held in conjunction with each Winter Meeting. The Society has approximately 50,000 members and has headquarters at Atlanta, Georgia, USA.

The most recognized standards for HVAC design is based on ASHRAE data. ASHRAE is the American Society of Heating, Refrigerating and Air-Conditioning Engineers. The ASHRAE Handbook's most general volume, of four, is Fundamentals; it includes heating and cooling calculations. Each volume of the ASHRAE Handbook is updated every four years. The design professional must consult ASHRAE data for the standards of design and care as the typical building codes provides little to no information on HVAC design practices; such codes, such as the UMC and IMC, do include much details on installation requirements, however. Other useful reference materials include items from SMACNA, ACCA, and technical trade journals.

American design standards are legislated in the Uniform Mechanical Code or International Mechanical Code. In certain states, counties, or cities, either of these codes may be adopted and amended via various legislative processes. These codes are updated and published by the International Association of Plumbing and Mechanical Officials (IAPMO) or the International Code Council (ICC) respectively, on a 3-year code development cycle. Typically, local Building Permit Departments are charged with enforcement of these standards on private and certain public properties.

In the United States, as well as throughout the world, HVAC contractors and companies are members of NADCA, the National Air Duct Cleaners Association. NADCA was formed in 1989 as a non-profit association of companies engaged in the cleaning of HVAC systems. Its mission was to promote source removal as the only acceptable method of cleaning and to establish industry standards for the association. NADCA has expanded its mission to include the representation of qualified companies engaged in the assessment, cleaning, and restoration of HVAC systems, and to assist its members in providing high quality service to their customers. The goal of the association is to be the number one source for the HVAC cleaning and restoration services: first time, every time. NADCA has experienced phenomenal membership growth and has been extremely successful with the training and certification of air systems cleaning specialists, mold remediators, and HVAC inspectors. The association has also published important standards and guidelines, educational materials, and other useful information for the consumer and members of NADCA. Their headquarters are located in Washington, D.C.

## **Europe**

### **United Kingdom**

The Chartered Institute of Building Services Engineers is a body that covers the essential Service (systems architecture) that allow buildings to operate. It includes the

electrotechnical, heating, ventilating, air conditioning, refrigeration and plumbing industries. To train as a building services engineer, the academic requirements are GCSEs (A-C) / Standard Grades (1-3) in Maths and Science, which are important in measurements, planning and theory. Employers will often want a degree in a branch of engineering, such as building environment engineering, electrical engineering or mechanical engineering. To become a full member of CIBSE, and so also to be registered by the Engineering Council UK as a chartered engineer, one must also attain an Honours Degree and a Masters Degree in a relevant engineering subject.

CIBSE publishes several guides to HVAC design relevant to the UK market, and also the Republic of Ireland, Australia, New Zealand and Hong Kong. These guides include various recommended design criteria and standards, some of which are cited within the UK building regulations, and therefore form a legislative requirement for major building services works. The main guides are:

- Guide A: Environmental Design
- Guide B: Heating, Ventilating, Air Conditioning and Refrigeration
- Guide C: Reference Data
- Guide D: Transportation systems in Buildings
- Guide E: Fire Safety Engineering
- Guide F: Energy Efficiency in Buildings
- Guide G: Public Health Engineering
- Guide H: Building Control Systems
- Guide J: Weather, Solar and Illuminance Data
- Guide K: Electricity in Buildings
- Guide L: Sustainability
- Guide M: Maintenance Engineering and Management

Within the construction sector, it is the job of the building services engineer to design and oversee the installation and maintenance of the essential services such as gas, electricity, water, heating and lighting, as well as many others. These all help to make buildings comfortable and healthy places to live and work in. Building Services is part of a sector that has over 51,000 businesses and employs represents 2%-3% of the GDP.

## **Australia**

Air Conditioning and Mechanical Contractors Association of Australia (AMCA)  
Australian Institute of Refrigeration, Air Conditioning and Heating (AIRAH),  
CIBSE

## **Asia**

### **India**

The Indian Society of Heating, Refrigerating and Air Conditioning Engineers (ISHRAE) was established to promote the HVAC industry in India. ISHRAE is an associate of

ASHRAE. ISHRAE was started at Delhi in 1981 and a chapter was started in Bangalore in 1989. Between 1989 & 1993, ISHRAE chapters were formed in all major cities in India and also in the Middle East.

### **Pakistan**

Air-conditioning technology has been in use in Pakistan since 1947, the time of its independence. At that point local expertise was dependent on the supply and installation of imported equipment in accordance with the system designs from abroad. Once Pakistani engineers recognized the importance of the field they became active in developing expertise in design, manufacture, installation, operation, and maintenance. In 1995 the Pakistan HVACR Society was formed. Since then, the Society started organizing various disciplines of the field under its umbrella.

## Chapter 2

# Building Automation

**Building automation** describes the functionality provided by the control system of a building. A building automation system (BAS) is an example of a distributed control system. The control system is a computerized, intelligent network of electronic devices, designed to monitor and control the mechanical and lighting systems in a building.

BAS core functionality keeps the building climate within a specified range, provides lighting based on an occupancy schedule, and monitors system performance and device failures and provides email and/or text notifications to building engineering staff. The BAS functionality reduces building energy and maintenance costs when compared to a non-controlled building. A building controlled by a BAS is often referred to as an intelligent building system.

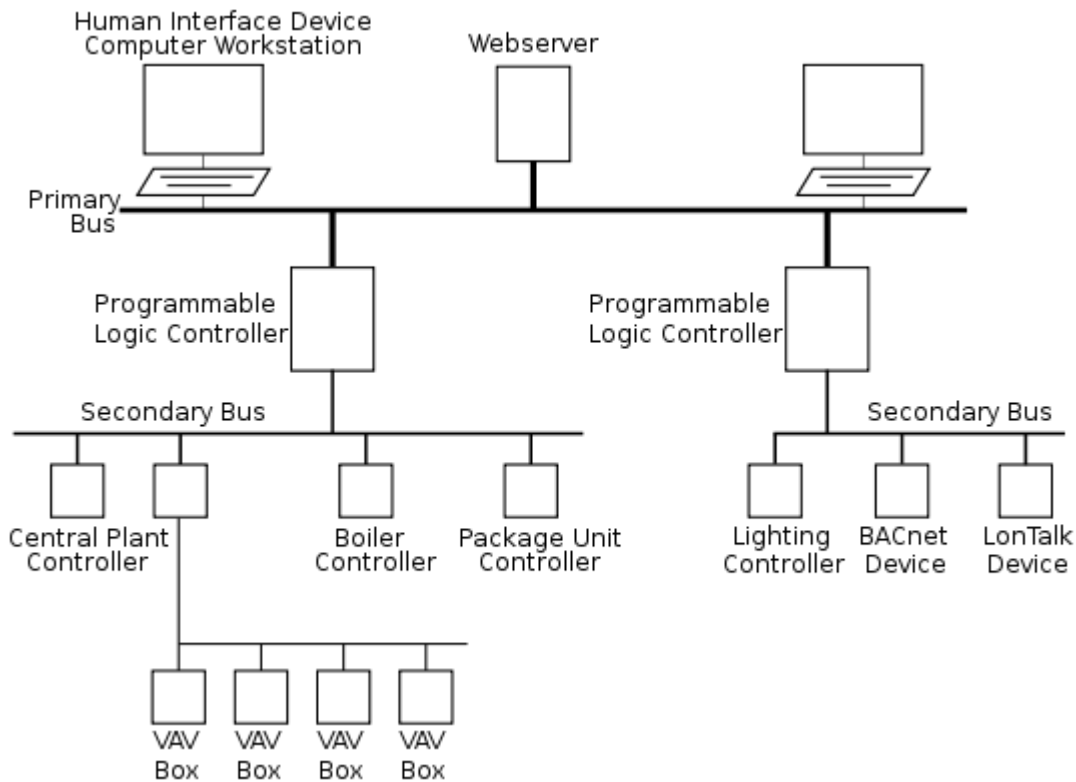

## Topology

Most building automation networks consist of a *primary* and *secondary* bus which connect high-level controllers (generally specialized for building automation, but may be generic programmable logic controllers) with lower-level controllers, input/output devices and a user interface (also known as a human interface device).

The primary and secondary bus can be BACnet, optical fiber, ethernet, ARCNET, RS-232, RS-485 or a wireless network.

Most controllers are proprietary. Each company has its own controllers for specific applications. Some are designed with limited controls: for example, a simple Packaged Roof Top Unit. Others are designed to be flexible. Most have proprietary software that will work with ASHRAE's open protocol BACnet or the open protocol LonTalk.

Some newer building automation and lighting control solutions use wireless mesh open standards (such as ZigBee). These systems can provide interoperability, allowing users to mix-and-match devices from different manufacturers, and to provide integration with other compatible building control systems.

Inputs and outputs are either analog or digital (some companies say binary).

Analog inputs are used to read a variable measurement. Examples are temperature, humidity and pressure sensor which could be thermistor, 4-20 mA, 0-10 volt or platinum resistance thermometer (resistance temperature detector), or wireless sensors.

A digital input indicates if a device is turned on or not. Some examples of an digital input would be a 24VDC/AC signal, an air flow switch, or a volta-free relay contact (Dry Contact).

Analog outputs control the speed or position of a device, such as a variable frequency drive, a I-P (current to pneumatics) transducer, or a valve or damper actuator. An example is a hot water valve opening up 25% to maintain a setpoint.

Digital outputs are used to open and close relays and switches. An example would be to turn on the parking lot lights when a photocell indicate it is dark outside.

## ***Infrastructure***

### **Controller**

Controllers are essentially small, purpose-built computers with input and output capabilities. These controllers come in a range of sizes and capabilities to control devices commonly found in buildings, and to control sub-networks of controllers.

Inputs allow a controller to read temperatures, humidity, pressure, current flow, air flow, and other essential factors. The outputs allow the controller to send command and control signals to slave devices, and to other parts of the system. Inputs and outputs can be either digital or analog. Digital outputs are also sometimes called discrete depending on manufacturer.

Controllers used for building automation can be grouped in 3 categories. Programmable Logic Controllers (PLCs), System/Network controllers, and Terminal Unit controllers. However an additional device can also exist in order to integrate 3rd party systems (i.e. a stand-alone AC system) into a central Building automation system).

PLC's provide the most responsiveness and processing power, but at a unit cost typically 2 to 3 times that of a System/Network controller intended for BAS applications. Terminal Unit controllers are usually the least expensive and least powerful.

PLC's may be used to automate high-end applications such as clean rooms or hospitals where the cost of the controllers is a lesser concern.

In office buildings, supermarkets, malls, and other common automated buildings the systems will use System/Network controllers rather than PLC's. Most System controllers provide general purpose feedback loops, as well as digital circuits, but lack the millisecond response time that PLC's provide.

System/Network controllers may be applied to control one or more mechanical systems such as an Air Handler Unit (AHU), boiler, chiller, etc., or they may supervise a sub-network of controllers. In the diagram above, System/Network controllers are often used in place of PLCs.

Terminal Unit controllers usually are suited for control of lighting and/or simpler devices such as a package rooftop unit, heat pump, VAV box, or fan coil, etc. The installer typically selects 1 of the available pre-programmed personalities best suited to the device to be controlled, and does not have to create new control logic.

## **Occupancy**

Occupancy is one of 2 or more operating modes for a building automation system. Unoccupied, Morning Warmup, and Night-time Setback are other common modes.

Occupancy is usually based on time of day schedules. In Occupancy mode, the BAS aims to provide a comfortable climate and adequate lighting, often with zone-based control so that users on one side of a building have a different thermostat (or a different system, or sub system) than users on the opposite side.

A temperature sensor in the zone provides feedback to the controller, so it can deliver heating or cooling as needed.

If enabled, Morning Warmup (MWU) mode occurs prior to Occupancy. During Morning Warmup the BAS tries to bring the building to setpoint just in time for Occupancy. The BAS often factors in outdoor conditions and historical experience to optimize MWU. This is also referred to as Optimised Start.

An override is a manually-initiated command to the BAS. For example, many wall-mounted temperature sensors will have a push-button that forces the system into Occupancy mode for a set number of minutes. Where present, web interfaces allow users to remotely initiate an override on the BAS.

Some buildings rely on occupancy sensors to activate lighting and/or climate conditioning. Given the potential for long lead times before a space becomes sufficiently cool or warm, climate conditioning is not often initiated directly by an occupancy sensor.

## **Lighting**

Lighting can be turned on, off, or dimmed with a building automation or lighting control system based on time of day, or on occupancy sensors, photosensors and timers. One typical example is to turn the lights in a space on for a half hour since the last motion was sensed. A photocell placed outside a building can sense darkness, and the time of day, and modulate lights in outer offices and the parking lot.

Lighting is also a good candidate for Demand response, with many control systems providing the ability to dim (or turn off) lights to take advantage of DR incentives and savings. If occupancy sensors are present they can also be used as burglar alarms

## **Air handlers**

Most air handlers mix return and outside air so less temperature change is needed. This can save money by using less chilled or heated water (not all AHUs use chilled/hot water circuits). Some external air is needed to keep the building's air healthy.

Analog or digital temperature sensors may be placed in the space or room, the return and supply air ducts, and sometimes the external air. Actuators are placed on the hot and chilled water valves, the outside air and return air dampers. The supply fan (and return if applicable) is started and stopped based on either time of day, temperatures, building pressures or a combination.

### **Constant volume air-handling units**

The less efficient type of air-handler is a "constant volume air handling unit," or CAV. The fans in CAVs do not have variable-speed controls. Instead, CAVs open and close dampers and water-supply valves to maintain temperatures in the building's spaces. They heat or cool the spaces by opening or closing chilled or hot water valves that feed their internal heat exchangers. Generally one CAV serves several spaces, but large buildings may have many CAVs.

### **Variable volume air-handling units**

A more efficient unit is a "variable air volume (VAV) air-handling unit," or VAV. VAVs supply pressurized air to VAV boxes, usually one box per room or area. A VAV air handler can change the pressure to the VAV boxes by changing the speed of a fan or blower with a variable frequency drive or (less efficiently) by moving inlet guide vanes to a fixed-speed fan. The amount of air is determined by the needs of the spaces served by the VAV boxes.

Each VAV box supply air to a small space, like an office. Each box has a damper that is opened or closed based on how much heating or cooling is required in its space. The more boxes are open, the more air is required, and a greater amount of air is supplied by the VAV air-handling unit.

Some VAV boxes also have hot water valves and an internal heat exchanger. The valves for hot and cold water are opened or closed based on the heat demand for the spaces it is supplying. These heated VAV boxes are sometimes used on the perimeter only and the interior zones are cooling only.

A minimum and maximum CFM must be set on VAV boxes to assure adequate ventilation and proper air balance.

## **VAV hybrid systems**

Another variation is a hybrid between VAV and CAV systems. In this system, the interior zones operate as in a VAV system. The outer zones differ in that the heating is supplied by a heating fan in a central location usually with a heating coil fed by the building boiler. The heated air is ducted to the exterior dual duct mixing boxes and dampers controlled by the zone thermostat calling for either cooled or heated air as needed.

## **Central plant**

A central plant is needed to supply the air-handling units with water. It may supply a chilled water system, hot water system and a condenser water system, as well as transformers and auxiliary power unit for emergency power. If well managed, these can often help each other. For example, some plants generate electric power at periods with peak demand, using a gas turbine, and then use the turbine's hot exhaust to heat water or power an absorptive chiller.

### **Chilled water system**

Chilled water is often used to cool a building's air and equipment. The chilled water system will have chiller(s) and pumps. Analog temperature sensors measure the chilled water supply and return lines. The chiller(s) are sequenced on and off to chill the chilled water supply.

### **Condenser water system**

Cooling tower(s) and pumps are used to supply cool condenser water to the chillers. Because the condenser water supply to the chillers has to be constant, variable speed drives are commonly used on the cooling tower fans to control temperature. Proper cooling tower temperature assures the proper refrigerant head pressure in the chiller. The cooling tower set point used depends upon the refrigerant being used. Analog temperature sensors measure the condenser water supply and return lines.

### **Hot water system**

The hot water system supplies heat to the building's air-handling unit or VAV box heating coils, along with the domestic hot water heating coils (Calorifier). The hot water system will have a boiler(s) and pumps. Analog temperature sensors are placed in the hot water supply and return lines. Some type of mixing valve is usually used to control the heating water loop temperature. The boiler(s) and pumps are sequenced on and off to maintain supply.

## Alarms and security

Many building automation systems have alarm capabilities. If an alarm is detected, it can be programmed to notify someone. Notification can be through a computer, pager, cellular phone, or audible alarm.

- Common temperature alarms are: space, supply air, chilled water supply and hot water supply.
- Differential pressure switches can be placed on the filter to determine if it is dirty.
- Status alarms are common. If a mechanical device like a pump is requested to start, and the status input indicates it is off. This can indicate a mechanical failure.
- Some valve actuators have end switches to indicate if the valve has opened or not.
- Carbon monoxide and carbon dioxide sensors can be used to alarm if levels are too high.
- Refrigerant sensors can be used to indicate a possible refrigerant leak.
- Current sensors can be used to detect low current conditions caused by slipping fan belts, or clogging strainers at pumps.

At sites with several buildings, momentary power failures can cause hundreds or thousands of alarms from equipment that has shut down. Some sites are programmed so that critical alarms are automatically re-sent at varying intervals. For example, a repeating critical alarm (of an [uninterruptible power supply] in 'by pass') might resound at 10 minutes, 30 minutes, and every 2 to 4 hours there after until the alarms are resolved.

Security systems can be interlocked to a building automation system. If occupancy sensors are present, they can also be used as burglar alarms.

Fire and smoke alarm systems can be hard-wired to override building automation. For example: if the smoke alarm is activated, all the outside air dampers close to prevent air coming into the building, and an exhaust system can isolate

## Room automation

**Room automation** is a subset of Building automation and like it, is the consolidation of one or systems under centralised control but in this case in just one room .

The most common example of *room automation* is corporate boardroom, presentation suites, and lecture halls, where the operation of the large number of devices that define the room function (such as Videoconferencing equipment, Video projectors, lighting control systems, Public address systems etc.) would make manual operation of the room very complex. It is common for room automation systems to employ a touchscreen as the primary way of controlling each operation.

## Chapter 3

# Central Heating



Central heating unit

A **central heating system** provides warmth to the whole interior of a building (or portion of a building) from one point to multiple rooms. When combined with other systems in order to control the building climate, the whole system may be a HVAC (heating, ventilation and air conditioning) system.

Central heating differs from local heating in that the heat generation occurs in one place, such as a furnace room in a house or a mechanical room in a large building (though not necessarily at the "central" geometric point). The most common method of heat generation involves the combustion of fossil fuel in a furnace or boiler. The resultant heat then gets distributed: typically by forced-air through ductwork, by water circulating through pipes, or by steam fed through pipes. Increasingly, buildings utilize solar-powered heat sources, in which case the distribution system normally uses water circulation.

In much of northern Europe and in urban portions of Russia, where people seldom require air conditioning in homes due to the temperate climate, most new housing comes with central heating installed. Such areas normally use gas heaters, district heating, or oil-fired systems. In the western and southern United States natural-gas-fired central forced-air systems occur most commonly; these systems and central-boiler systems both occur in the far northern regions of the USA. Steam-heating systems, fired by coal, oil or gas, feature in the USA, Russia and Europe: primarily for larger buildings. Electrical heating systems occur less commonly and are only practical with low cost electricity or when geothermal heat pumps are used. Considering the combined system of central generating plant and electric resistance heating, the overall efficiency will be less than for direct use of fossil fuel for space heating.

## History



The Summer Palace of Peter the Great in St. Petersburg, one of the first buildings to incorporate the modern-type hydrologic central heating.

Some buildings in the Roman Empire used central heating systems, conducting air heated by furnaces through empty spaces under the floors and out of pipes in the walls — a system known as a *hypocaust*. A similar system of central heating was used in ancient Korea, where it is known as *ondol*. It is thought that the *ondol* system dates back to the Koguryo or Three Kingdoms (37 BC-AD 668) period when excess heat from stoves were used to warm homes.

The hypocaust continued to be used in the Mediterranean region during late Antiquity and by the Umayyad caliphate. By the 12th century, Muslim engineers in Syria introduced a central heating system, where heat travelled through underfloor pipes from the furnace room, rather than through a hypocaust. This central heating system was widely used in bath-houses throughout the medieval Islamic world.

In the 13th century, the Cistercian monks revived central heating in Christian Europe using river diversions combined with indoor wood-fired furnaces. The well-preserved Royal Monastery of Our Lady of the Wheel (founded 1202) on the Ebro River in the Aragon region of Spain provides an excellent example of such an application.

By about 1700 Russian engineers had started designing hydrologically based systems for central heating. The Summer Palace (1710–1714) of Peter the Great in Saint Petersburg provides the best extant example. Slightly later, in 1716, came the first use of water in Sweden to distribute heat in buildings. Martin Triewald, a Swedish engineer, used this method for a greenhouse at Newcastle upon Tyne. Jean Simon Bonnemain (1743–1830), a French architect, introduced the technique to industry on a cooperative, at Château du Pêcq, near Paris.

Angier March Perkins developed and installed some of the earliest steam-heating systems in the 1830s. The first was installed in the home of Governor of the Bank of England John Horley Palmer so that he could grow grapes in England's cold climate.

Franz San Galli, a Polish-born Russian businessman living in St. Petersburg, invented the radiator between 1855-1857, which was a major step in the final shaping of modern central heating.

## ***Water heating***

Common components of a central heating system using water-circulation include:

- Gas supply lines (sometimes including a propane tank), oil tank and supply lines or district heating supply lines
- Boiler (or a heat exchanger for district heating) — heats water in a closed-water system
- Pump — circulates the water in the closed system
- Radiators — wall-mounted panels through which the heated water passes in order to release heat into rooms

Engineers in the United Kingdom and in other parts of Europe commonly combine the needs of room heating with hot-water heating and storage. These systems occur less commonly in the USA. In this case, the heated water in a sealed system flows through a heat exchanger in a hot-water tank or hot-water cylinder where it heats water from the normal water supply before that water gets fed to hot-water outlets in the house. These outlets may service hot-water taps or appliances such as washing machines or dishwashers.



Expansion tank.

### **Sealed water-circulating system**

A sealed system provides a form of central heating in which the water used for heating usually circulates independently of the building's normal water supply. An expansion tank contains compressed gas, separated from the sealed-system water by a diaphragm. This allows for normal variations of pressure in the system. A safety valve allows water to escape from the system when pressure becomes too high, and a valve can open to replenish water from the normal water supply if the pressure drops too low. Sealed systems offer an alternative to open-vent systems, in which steam can escape from the system, and gets replaced from the building's water supply via a feed and central storage system.

## ***Electric and gas-fired heaters***

Electric heating or resistance heating converts electricity directly to heat. Electric heat is often more expensive than heat produced by combustion appliances like natural gas, propane, and oil. Electric resistance heat can be provided by baseboard heaters, space heaters, radiant heaters, furnaces, wall heaters, or thermal storage systems.

Electric heaters are usually part of a fan coil which is part of a central air conditioner. They circulate heat by blowing air across the heating element which is supplied to the furnace through return air ducts. Blowers in electric furnaces move air over one to five resistance coils or elements which are usually rated at five kilowatts. The heating elements activate one at a time to avoid overloading the electrical system. Overheating is prevented by a safety switch called a limit controller or limit switch. This limit controller may shut the furnace off if the blower fails or if something is blocking the air flow. The heated air is then sent back through the home through supply ducts.

In larger commercial applications, central heating is provided through an air handler which incorporates similar components as a furnace but on a larger scale.

## ***Hydronic and steam systems***

Hydronic heating systems are systems that circulate a medium for heating. Hydronic radiant floor heating systems use a boiler or district heating to heat water and a pump to circulate the hot water in plastic pipes installed in a concrete slab. The pipes, embedded in the floor, carry heated water that conducts warmth to the surface of the floor where it broadcasts heat energy to the room above.

Hydronic systems circulate hot water for heating. Steam heating systems are similar to heating water systems, except steam is used as the heating medium instead of water.

Hydronic heating systems generally consist of a boiler or district heating heat exchanger, hot water circulating pumps, distribution piping, and a fan coil unit or a radiator located in the room or space. Steam heating systems are similar except no circulating pumps are required.

Hydronic systems are closed loop: the same fluid is heated and then reheated. Hydronic heating systems are also used with antifreeze solutions in ice and snow melt systems for walkways, parking lots and streets. They are more commonly used in commercial and whole house radiant floor heat projects, while electric radiant heat systems are more commonly used in smaller "spot warming" applications.

## ***Heat pumps***

In mild climates a heat pump can be used to air condition the building during hot weather, and to warm the building using heat extracted from outdoor air in cold weather. Air-source heat pumps are generally uneconomic for outdoor temperatures much below

freezing. In colder climates, geothermal heat pumps can be used to extract heat from the ground. For economy, these systems are designed for average low winter temperatures and use supplemental heating for extreme low temperature conditions. The advantage of the heat pump is that it reduces the purchased energy required for building heating; often geothermal source systems also supply domestic hot water. Even in places where fossil fuels provide most electricity, a geothermal system may offset greenhouse gas production since most of the energy furnished for heating is supplied from the environment, with only 15–30% purchased.

### ***Environmental aspects***

From an energy-efficiency standpoint considerable heat gets lost or goes to waste if only a single room needs heating, since central heating has distribution losses and (in the case of forced-air systems particularly) may heat some unoccupied rooms without need. In such buildings which require isolated heating, one may wish to consider non-central systems such as individual room heaters, fireplaces or other devices. Alternatively, architects can design new buildings to use low-energy building techniques which can virtually eliminate the need for heating, such as those built to the Passive House standard.

However, if a building does need full heating, combustion central heating offers a more environmentally friendly solution than electric-air central heating or than other direct electric heating devices. This stems from the fact that most electricity originates remotely using fossil fuels, with up to two-thirds of the energy in the fuel lost (unless utilized for district heating) at the power station and in transmission losses. In Sweden proposals exist to phase out direct electric heating for this reason. Nuclear and hydroelectric sources reduce this factor.

In contrast, hot-water central heating systems can use water heated in or close to the building using high-efficiency condensing boilers, biofuels, or district heating. Wet underfloor heating has proven ideal. This offers the option of relatively easy conversion in the future to use developing technologies such as heat pumps and solar combisystems, thereby also providing future-proofing.

Typical efficiencies for central heating are: 85-97% for gas fired heating; 80-89% for oil-fired, and 45-60% for coal-fired heating.

## Chapter 4

# Heat Exchanger



An interchangeable plate heat exchanger

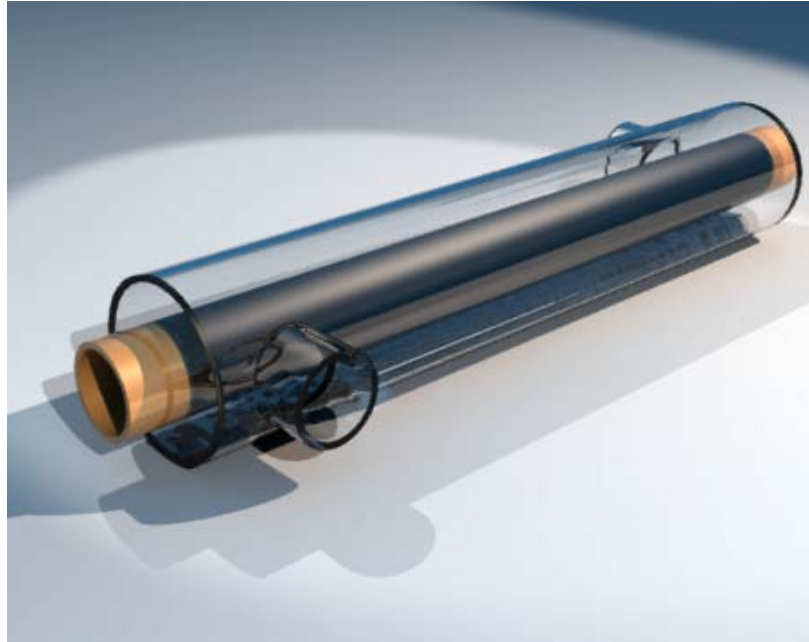

Tubular heat exchanger.

A **heat exchanger** is a piece of equipment built for efficient heat transfer from one medium to another. The media may be separated by a solid wall, so that they never mix, or they may be in direct contact. They are widely used in space heating, refrigeration, air conditioning, power plants, chemical plants, petrochemical plants, petroleum refineries, natural gas processing, and sewage treatment. One common example of a heat exchanger is the radiator in a car, in which the heat source, being a hot engine-cooling fluid, water, transfers heat to air flowing through the radiator (i.e. the heat transfer medium).

### ***Flow arrangement***

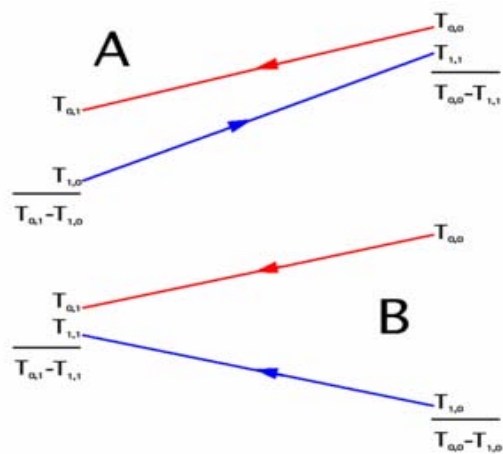

Countercurrent (A) and parallel (B) flows

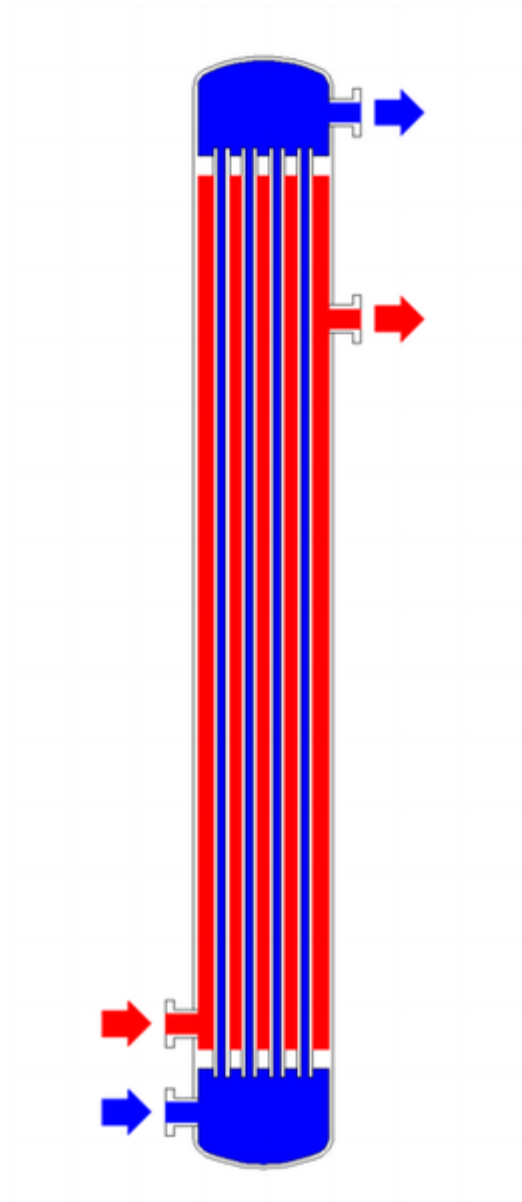

Fig. 1: Shell and tube heat exchanger, single pass (1-1 parallel flow)

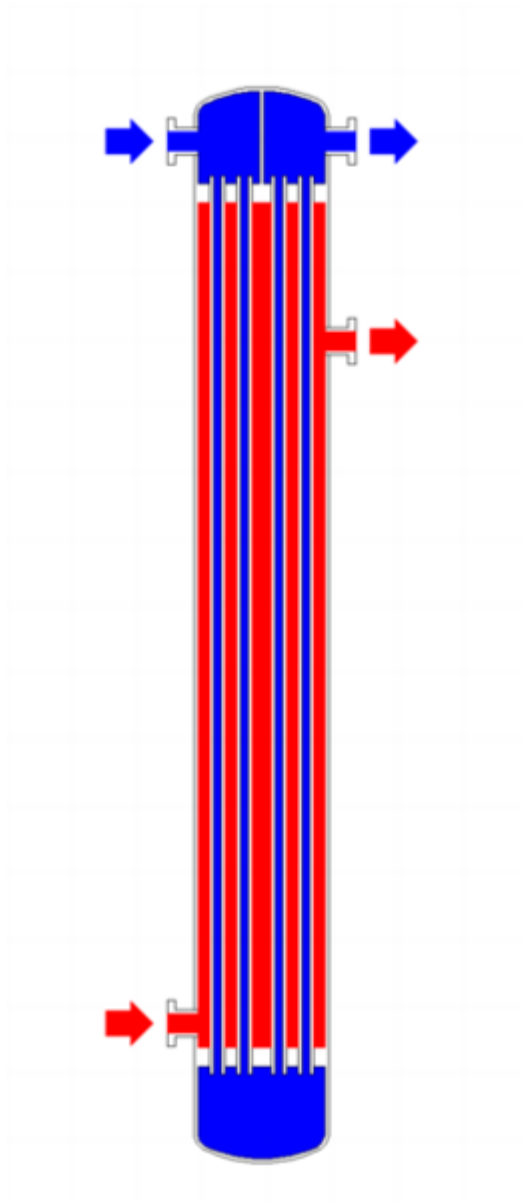

Fig. 2: Shell and tube heat exchanger, 2-pass tube side (1-2 crossflow)

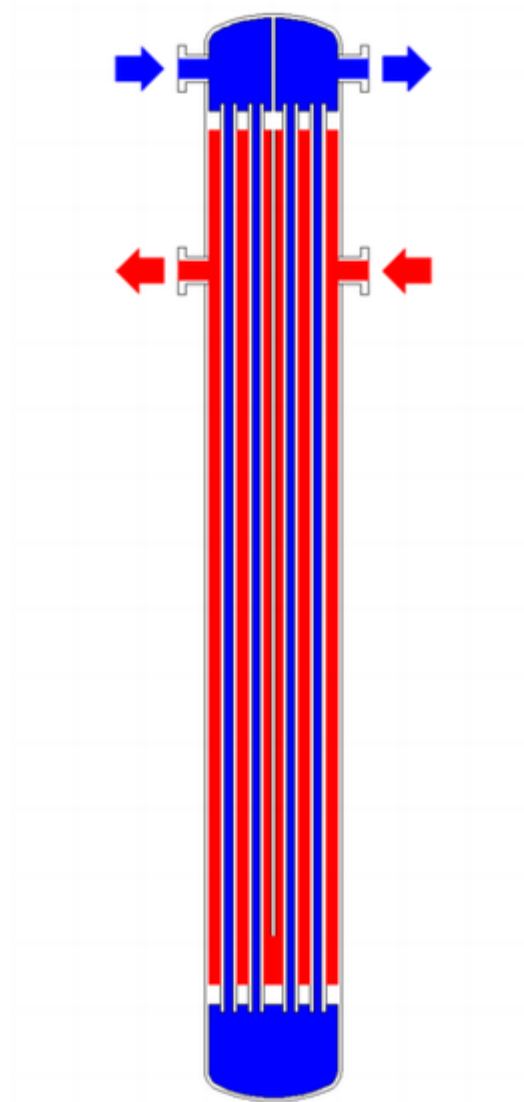

Fig. 3: Shell and tube heat exchanger, 2-pass shell side, 2-pass tube side (2-2 countercurrent)

There are two primary classifications of heat exchangers according to their flow arrangement. In *parallel-flow* heat exchangers, the two fluids enter the exchanger at the same end, and travel in parallel to one another to the other side. In *counter-flow* heat exchangers the fluids enter the exchanger from opposite ends. The counter current design is most efficient, in that it can transfer the most heat from the heat (transfer) medium.

For efficiency, heat exchangers are designed to maximize the surface area of the wall between the two fluids, while minimizing resistance to fluid flow through the exchanger. The exchanger's performance can also be affected by the addition of fins or corrugations

in one or both directions, which increase surface area and may channel fluid flow or induce turbulence.

The driving temperature across the heat transfer surface varies with position, but an appropriate mean temperature can be defined. In most simple systems this is the "log mean temperature difference" (LMTD). Sometimes direct knowledge of the LMTD is not available and the NTU method is used.

## ***Types of heat exchangers***

### **Shell and tube heat exchanger**

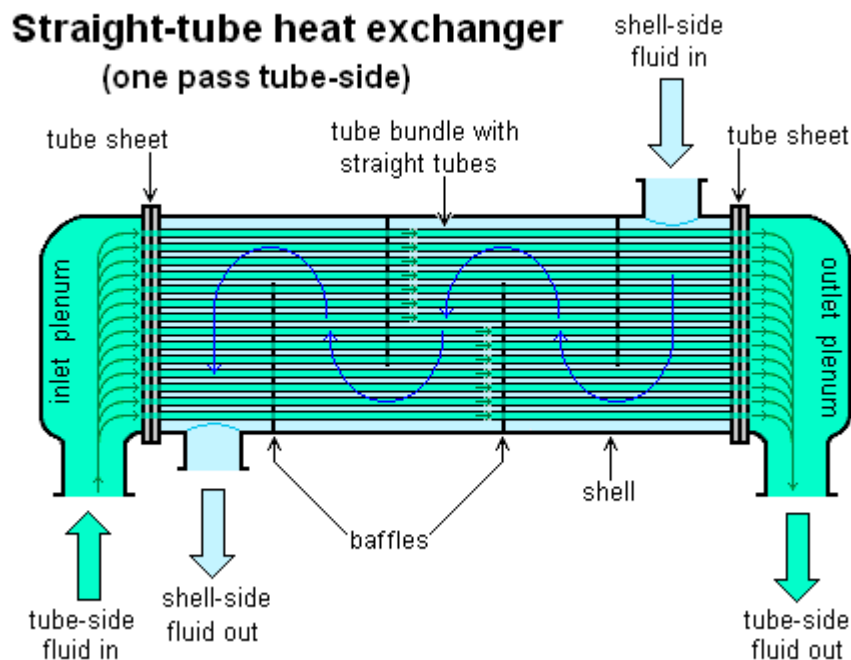

A Shell and Tube heat exchanger

Shell and tube heat exchangers consist of a series of tubes. One set of these tubes contains the fluid that must be either heated or cooled. The second fluid runs over the tubes that are being heated or cooled so that it can either provide the heat or absorb the heat required. A set of tubes is called the tube bundle and can be made up of several types of tubes: plain, longitudinally finned, etc. Shell and tube heat exchangers are typically used for high-pressure applications (with pressures greater than 30 bar and temperatures greater than 260°C). This is because the shell and tube heat exchangers are robust due to their shape.

There are several thermal design features that are to be taken into account when designing the tubes in the shell and tube heat exchangers. These include:

- Tube diameter: Using a small tube diameter makes the heat exchanger both economical and compact. However, it is more likely for the heat exchanger to foul

- up faster and the small size makes mechanical cleaning of the fouling difficult. To prevail over the fouling and cleaning problems, larger tube diameters can be used. Thus to determine the tube diameter, the available space, cost and the fouling nature of the fluids must be considered.
- Tube thickness: The thickness of the wall of the tubes is usually determined to ensure:
    - There is enough room for corrosion
    - That flow-induced vibration has resistance
    - Axial strength
    - Availability of spare parts
    - Hoop strength (to withstand internal tube pressure)
    - Buckling strength (to withstand overpressure in the shell)
  - Tube length: heat exchangers are usually cheaper when they have a smaller shell diameter and a long tube length. Thus, typically there is an aim to make the heat exchanger as long as physically possible whilst not exceeding production capabilities. However, there are many limitations for this, including the space available at the site where it is going to be used and the need to ensure that there are tubes available in lengths that are twice the required length (so that the tubes can be withdrawn and replaced). Also, it has to be remembered that long, thin tubes are difficult to take out and replace.
  - Tube pitch: when designing the tubes, it is practical to ensure that the tube pitch (i.e., the centre-centre distance of adjoining tubes) is not less than 1.25 times the tubes' outside diameter. A larger tube pitch leads to a larger overall shell diameter which leads to a more expensive heat exchanger.
  - Tube corrugation: this type of tubes, mainly used for the inner tubes, increases the turbulence of the fluids and the effect is very important in the heat transfer giving a better performance.
  - Tube Layout: refers to how tubes are positioned within the shell. There are four main types of tube layout, which are, triangular ( $30^\circ$ ), rotated triangular ( $60^\circ$ ), square ( $90^\circ$ ) and rotated square ( $45^\circ$ ). The triangular patterns are employed to give greater heat transfer as they force the fluid to flow in a more turbulent fashion around the piping. Square patterns are employed where high fouling is experienced and cleaning is more regular.
  - Baffle Design: baffles are used in shell and tube heat exchangers to direct fluid across the tube bundle. They run perpendicularly to the shell and hold the bundle, preventing the tubes from sagging over a long length. They can also prevent the tubes from vibrating. The most common type of baffle is the segmental baffle. The semicircular segmental baffles are oriented at  $180$  degrees to the adjacent baffles forcing the fluid to flow upward and downwards between the tube bundle. Baffle spacing is of large thermodynamic concern when designing shell and tube heat exchangers. Baffles must be spaced with consideration for the conversion of pressure drop and heat transfer. For thermo economic optimization it is suggested that the baffles be spaced no closer than 20% of the shell's inner diameter. Having baffles spaced too closely causes a greater pressure drop because of flow redirection. Consequently having the baffles spaced too far apart means that there may be cooler spots in the corners between baffles. It is also important to ensure

the baffles are spaced close enough that the tubes do not sag. The other main type of baffle is the disc and donut baffle which consists of two concentric baffles, the outer wider baffle looks like a donut, whilst the inner baffle is shaped as a disk. This type of baffle forces the fluid to pass around each side of the disk then through the donut baffle generating a different type of fluid flow.

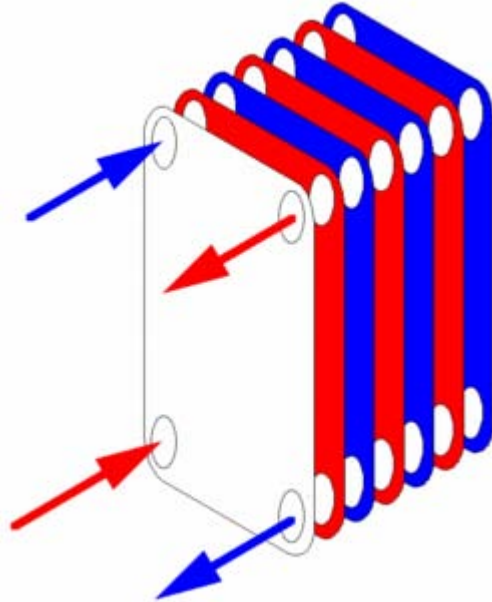

Conceptual diagram of a plate and frame heat exchanger.



A single plate heat exchanger



An interchangeable plate heat exchanger applied to the system of a swimming pool

### **Plate heat exchanger**

Another type of heat exchanger is the plate heat exchanger. One is composed of multiple, thin, slightly-separated plates that have very large surface areas and fluid flow passages for heat transfer. This stacked-plate arrangement can be more effective, in a given space, than the shell and tube heat exchanger. Advances in gasket and brazing technology have made the plate-type heat exchanger increasingly practical. In HVAC applications, large heat exchangers of this type are called *plate-and-frame*; when used in open loops, these heat exchangers are normally of the gasket type to allow periodic disassembly, cleaning, and inspection. There are many types of permanently-bonded plate heat exchangers, such as dip-brazed and vacuum-brazed plate varieties, and they are often specified for closed-

loop applications such as refrigeration. Plate heat exchangers also differ in the types of plates that are used, and in the configurations of those plates. Some plates may be stamped with "chevron" or other patterns, where others may have machined fins and/or grooves.

### **Adiabatic wheel heat exchanger**

A third type of heat exchanger uses an intermediate fluid or solid store to hold heat, which is then moved to the other side of the heat exchanger to be released. Two examples of this are adiabatic wheels, which consist of a large wheel with fine threads rotating through the hot and cold fluids, and fluid heat exchangers.

### **Plate fin heat exchanger**

This type of heat exchanger uses "sandwiched" passages containing fins to increase the effectivity of the unit. The designs include crossflow and counterflow coupled with various fin configurations such as straight fins, offset fins and wavy fins.

Plate and fin heat exchangers are usually made of aluminium alloys which provide higher heat transfer efficiency. The material enables the system to operate at a lower temperature and reduce the weight of the equipment. Plate and fin heat exchangers are mostly used for low temperature services such as natural gas, helium and oxygen liquefaction plants, air separation plants and transport industries such as motor and aircraft engines.

Advantages of plate and fin heat exchangers:

- High heat transfer efficiency especially in gas treatment
- Larger heat transfer area
- Approximately 5 times lighter in weight than that of shell and tube heat exchanger
- Able to withstand high pressure

Disadvantages of plate and fin heat exchangers:

- Might cause clogging as the pathways are very narrow
- Difficult to clean the pathways
- Aluminum alloys are susceptible to Mercury Liquid Embrittlement Failure

### **Pillow plate heat exchanger**

A pillow plate exchanger is commonly used in the dairy industry for cooling milk in large direct-expansion stainless steel bulk tanks. The pillow plate allows for cooling across nearly the entire surface area of the tank, without gaps that would occur between pipes welded to the exterior of the tank.

The pillow plate is constructed using a thin sheet of metal spot-welded to the surface of another thicker sheet of metal. The thin plate is welded in a regular pattern of dots or with

a serpentine pattern of weld lines. After welding the enclosed space is pressurized with sufficient force to cause the thin metal to bulge out around the welds, providing a space for heat exchanger liquids to flow, and creating a characteristic appearance of a swelled pillow formed out of metal.

## Fluid heat exchangers

This is a heat exchanger with a gas passing upwards through a shower of fluid (often water), and the fluid is then taken elsewhere before being cooled. This is commonly used for cooling gases whilst also removing certain impurities, thus solving two problems at once. It is widely used in espresso machines as an energy-saving method of cooling super-heated water to be used in the extraction of espresso.

## Waste heat recovery units

A Waste Heat Recovery Unit (WHRU) is a heat exchanger that recovers heat from a hot gas stream while transferring it to a working medium, typically water or oils. The hot gas stream can be the exhaust gas from a gas turbine or a diesel engine or a waste gas from industry or refinery.

## Dynamic scraped surface heat exchanger

Another type of heat exchanger is called "(dynamic) scraped surface heat exchanger". This is mainly used for heating or cooling with high-viscosity products, crystallization processes, evaporation and high-fouling applications. Long running times are achieved due to the continuous scraping of the surface, thus avoiding fouling and achieving a sustainable heat transfer rate during the process.

The formula used for this will be  $Q=A*U*LMTD$ , whereby  $Q$ = heat transfer rate.

## Phase-change heat exchangers

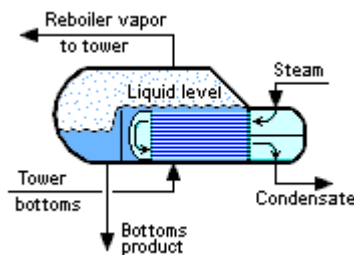

Typical kettle reboiler used for industrial distillation towers

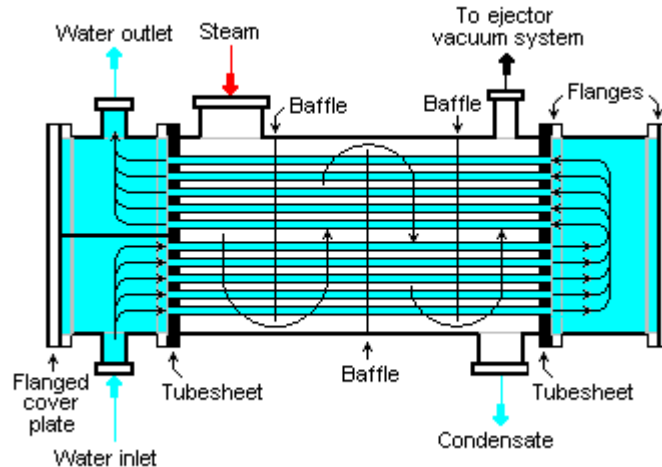

Typical water-cooled surface condenser

In addition to heating up or cooling down fluids in just a single phase, heat exchangers can be used either to heat a liquid to evaporate (or boil) it or used as condensers to cool a vapor and condense it to a liquid. In chemical plants and refineries, reboilers used to heat incoming feed for distillation towers are often heat exchangers.

Distillation set-ups typically use condensers to condense distillate vapors back into liquid.

Power plants which have steam-driven turbines commonly use heat exchangers to boil water into steam. Heat exchangers or similar units for producing steam from water are often called boilers or steam generators.

In the nuclear power plants called pressurized water reactors, special large heat exchangers which pass heat from the primary (reactor plant) system to the secondary (steam plant) system, producing steam from water in the process, are called steam generators. All fossil-fueled and nuclear power plants using steam-driven turbines have surface condensers to convert the exhaust steam from the turbines into condensate (water) for re-use.

To conserve energy and cooling capacity in chemical and other plants, regenerative heat exchangers can be used to transfer heat from one stream that needs to be cooled to another stream that needs to be heated, such as distillate cooling and reboiler feed pre-heating.

This term can also refer to heat exchangers that contain a material within their structure that has a change of phase. This is usually a solid to liquid phase due to the small volume difference between these states. This change of phase effectively acts as a buffer because it occurs at a constant temperature but still allows for the heat exchanger to accept additional heat. One example where this has been investigated is for use in high power aircraft electronics.

## **Direct contact heat exchangers**

Direct contact heat exchangers involve heat transfer between hot and cold streams of two phases in the absence of a separating wall. Thus such heat exchangers can be classified as:

- Gas – liquid
- Immiscible liquid – liquid
- Solid-liquid or solid – gas

Most direct contact heat exchangers fall under the Gas- Liquid category, where heat is transferred between a gas and liquid in the form of drops, films or sprays.

Such types of heat exchangers are used predominantly in air conditioning, humidification, water cooling and condensing plants.

<b>Phases</b>	<b>Continuous phase</b>	<b>Driving force</b>	<b>Change of phase</b>	<b>Examples</b>
Gas – Liquid	Gas	Gravity	No	Spray columns, packed columns
			Yes	Cooling towers, falling droplet evaporators
		Forced Liquid flow	No	Spray coolers/quenchers
			Yes	Spray condensers/evaporation, jet condensers
	Liquid	Gravity	No	Bubble columns, perforated tray columns
			Yes	Bubble column condensers
		Forced Gas flow	No	Gas spargers
			Yes	Direct contact evaporators, submerged combustion

## **HVAC air coils**

One of the widest uses of heat exchangers is for air conditioning of buildings and vehicles. This class of heat exchangers is commonly called *air coils*, or just *coils* due to their often-serpentine internal tubing. Liquid-to-air, or air-to-liquid HVAC coils are typically of modified crossflow arrangement. In vehicles, heat coils are often called heater cores.

On the liquid side of these heat exchangers, the common fluids are water, a water-glycol solution, steam, or a refrigerant. For *heating coils*, hot water and steam are the most common, and this heated fluid is supplied by boilers, for example. For *cooling coils*, chilled water and refrigerant are most common. Chilled water is supplied from a chiller

that is potentially located very far away, but refrigerant must come from a nearby condensing unit. When a refrigerant is used, the cooling coil is the evaporator in the vapor-compression refrigeration cycle. HVAC coils that use this direct-expansion of refrigerants are commonly called *DX coils*.

On the air side of HVAC coils a significant difference exists between those used for heating, and those for cooling. Due to psychrometrics, air that is cooled often has moisture condensing out of it, except with extremely dry air flows. Heating some air increases that airflow's capacity to hold water. So heating coils need not consider moisture condensation on their air-side, but cooling coils *must* be adequately designed and selected to handle their particular *latent* (moisture) as well as the *sensible* (cooling) loads. The water that is removed is called *condensate*.

For many climates, water or steam HVAC coils can be exposed to freezing conditions. Because water expands upon freezing, these somewhat expensive and difficult to replace thin-walled heat exchangers can easily be damaged or destroyed by just one freeze. As such, freeze protection of coils is a major concern of HVAC designers, installers, and operators.

The introduction of indentations placed within the heat exchange fins controlled condensation, allowing water molecules to remain in the cooled air. This invention allowed for refrigeration without icing of the cooling mechanism.

The heat exchangers in direct-combustion furnaces, typical in many residences, are not 'coils'. They are, instead, gas-to-air heat exchangers that are typically made of stamped steel sheet metal. The combustion products pass on one side of these heat exchangers, and air to be conditioned on the other. A *cracked heat exchanger* is therefore a dangerous situation requiring immediate attention because combustion products are then likely to enter the building.

## ***Spiral heat exchangers***

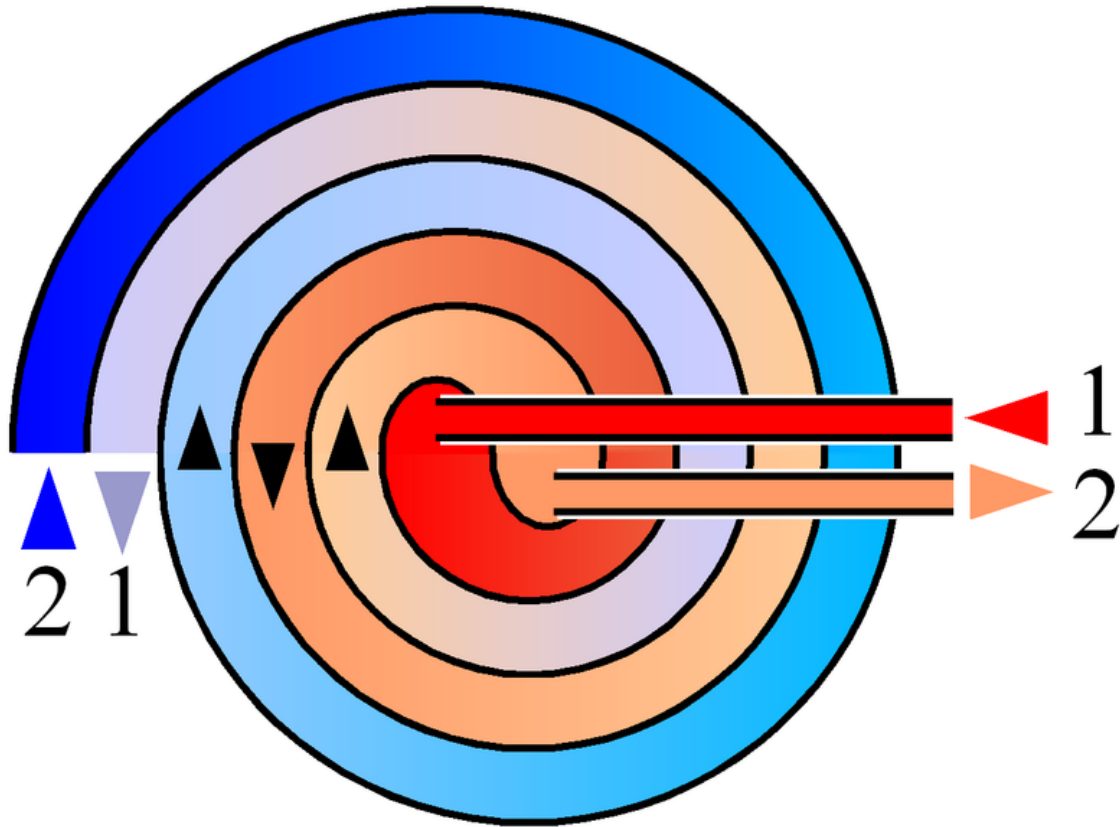

Schematic drawing of a spiral heat exchanger.

A spiral heat exchanger (SHE), may refer to a helical (coiled) tube configuration, more generally, the term refers to a pair of flat surfaces that are coiled to form the two channels in a counter-flow arrangement. Each of the two channels has one long curved path. A pair of fluid ports are connected tangentially to the outer arms of the spiral, and axial ports are common, but optional.

The main advantage of the SHE is its highly efficient use of space. This attribute is often leveraged and partially reallocated to gain other improvements in performance, according to well known tradeoffs in heat exchanger design. (A notable tradeoff is capital cost vs operating cost.) A compact SHE may be used to have a smaller footprint and thus lower all-around capital costs, or an over-sized SHE may be used to have less pressure drop, less pumping energy, higher thermal efficiency, and lower energy costs.

### **Construction**

The distance between the sheets in the spiral channels are maintained by using spacer studs that were welded prior to rolling. Once the main spiral pack has been rolled, alternate top and bottom edges are welded and each end closed by a gasketed flat or conical cover bolted to the body. This ensures no mixing of the two fluids will occur. If a

leakage happens, it will be from the periphery cover to the atmosphere, or to a passage containing the same fluid.

## Self cleaning

SHEs are often used in the heating of fluids which contain solids and thus have a tendency to foul the inside of the heat exchanger. The low pressure drop gives the SHE its ability to handle fouling easier. The SHE uses a “self cleaning” mechanism, whereby fouled surfaces cause a localized increase in fluid velocity, thus increasing the drag (or fluid friction) on the fouled surface, thus helping to dislodge the blockage and keep the heat exchanger clean. "The internal walls that make up the heat transfer surface are often rather thick, which makes the SHE very robust, and able to last a long time in demanding environments." They are also easily cleaned, opening out like an oven where any build up of foulant can be removed by pressure washing.

Self-Cleaning Water filters are used to keep the system clean and running without the need to shut down or replace cartridges and bags.

## Flow Arrangements

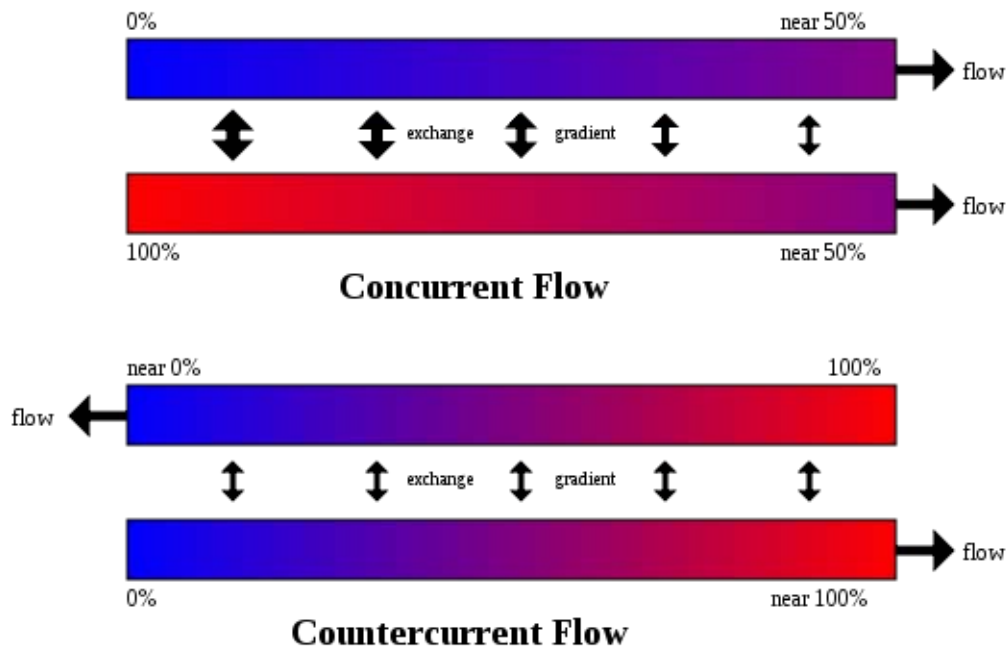

Concurrent and countercurrent flow.

There are three main types of flows in a spiral heat exchanger:

1. **Countercurrent Flow:** Fluids flow in opposite directions. These are used for liquid-liquid, condensing and gas cooling applications. Units are usually mounted vertically when condensing vapour and mounted horizontally when handling high concentrations of solids.
2. **Spiral Flow/Cross Flow:** One fluid is in spiral flow and the other in a cross flow. Spiral flow passages are welded at each side for this type of spiral heat exchanger. This type of flow is suitable for handling low density gases which passes through the cross flow, avoiding pressure loss. It can be used for liquid-liquid applications if one liquid has a considerably greater flow rate than the other.
3. **Distributed Vapour/Spiral flow:** This design is a condenser, and is usually mounted vertically. It is designed to cater for the sub-cooling of both condensate and non-condensables. The coolant moves in a spiral and leaves via the top. Hot gases that enter leave as condensate via the bottom outlet.

## Applications

The SHE is good for applications such as pasteurization, digester heating, heat recovery, pre-heating (see: recuperator), and effluent cooling. For sludge treatment, SHEs are generally smaller than other types of heat exchangers.

## Selection

Due to the many variables involved, selecting optimal heat exchangers is challenging. Hand calculations are possible, but many iterations are typically needed. As such, heat exchangers are most often selected via computer programs, either by system designers, who are typically engineers, or by equipment vendors.

In order to select an appropriate heat exchanger, the system designers (or equipment vendors) would firstly consider the design limitations for each heat exchanger type. Although cost is often the first criterion evaluated, there are several other important selection criteria which include:

- High/ Low pressure limits
- Thermal Performance
- Temperature ranges
- Product Mix (liquid/liquid, particulates or high-solids liquid)
- Pressure Drops across the exchanger
- Fluid flow capacity
- Cleanability, maintenance and repair
- Materials required for construction
- Ability and ease of future expansion

Choosing the right heat exchanger (HX) requires some knowledge of the different heat exchanger types, as well as the environment in which the unit must operate. Typically in the manufacturing industry, several differing types of heat exchangers are used for just the one process or system to derive the final product. For example, a kettle HX for pre-

heating, a double pipe HX for the ‘carrier’ fluid and a plate and frame HX for final cooling. With sufficient knowledge of heat exchanger types and operating requirements, an appropriate selection can be made to optimise the process.

### ***Monitoring and maintenance***

Online monitoring of commercial heat exchangers is done by tracking the overall heat transfer coefficient. The overall heat transfer coefficient tends to decline over time due to fouling.

$$U=Q/A\Delta T_{lm}$$

By periodically calculating the overall heat transfer coefficient from exchanger flow rates and temperatures, the owner of the heat exchanger can estimate when cleaning the heat exchanger will be economically attractive.

Integrity inspection of plate and tubular heat exchanger can be tested in situ by the conductivity or helium gas methods. These methods confirm the integrity of the plates or tubes to prevent any cross contamination and the condition of the gaskets.

Mechanical integrity monitoring of heat exchanger tubes may be conducted through Nondestructive methods such as eddy current testing.

### **Fouling**

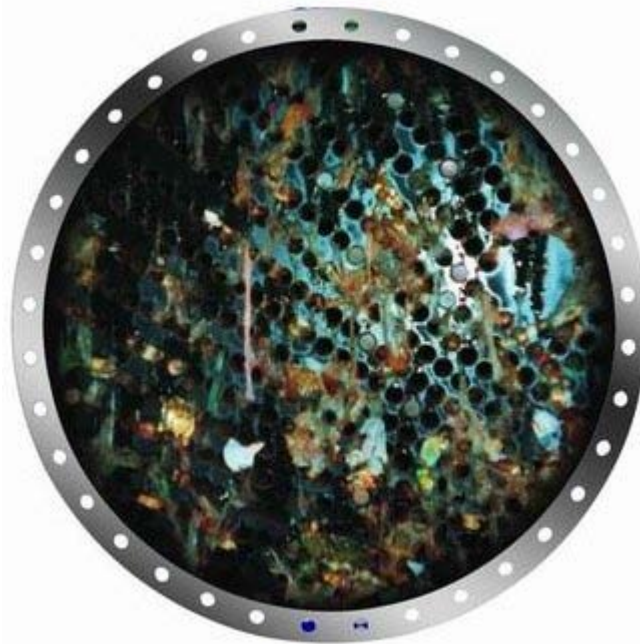

A heat exchanger in a steam power station contaminated with macrofouling.

Fouling occurs when impurities deposit on the heat exchange surface. Deposition of these impurities can be caused by:

- Low wall shear stress
- Low fluid velocities
- High fluid velocities
- Reaction product solid precipitation
- Precipitation of dissolved impurities due to elevated wall temperatures

The rate of heat exchanger fouling is determined by the rate of particle deposition less re-entrainment/suppression. This model was originally proposed in 1959 by Kern and Seaton.

**Crude Oil Exchanger Fouling.** In commercial crude oil refining, crude oil is heated from 70F to 650F prior to entering the distillation column. A series of shell and tube heat exchangers is typically used to exchange heat between the crude oil and other oil streams, in order to get the crude to 500F prior to heating in a furnace. Fouling occurs on the crude side of these exchangers due to asphaltene insolubility. The nature of asphaltene solubility in crude oil was successfully modeled by Wiehe and Kennedy. The precipitation of insoluble asphaltenes in crude preheat trains has been successfully modeled as a first order reaction by Ebert and Panchal who expanded on the work of Kern and Seaton.

**Cooling Water Fouling.** Cooling water systems are susceptible to fouling. Cooling water typically has a high total dissolved solids content and suspended colloidal solids. Localized precipitation of dissolved solids occurs at the heat exchange surface due to wall temperatures higher than bulk fluid temperature. Low fluid velocities allow suspended solids to settle on the heat exchange surface. Cooling water is typically on the tube side of a shell and tube exchanger because it's easy to clean. To prevent fouling, designers typically ensure that cooling water velocity is greater than 3 ft/s and bulk fluid temperature is maintained less than 140F. Other approaches to control fouling control combine the “blind” application of biocides and anti-scale chemicals with periodic lab testing.

## **Maintenance**

Plate heat exchangers need to be disassembled and cleaned periodically. Tubular heat exchangers can be cleaned by such methods as acid cleaning, sandblasting, high-pressure water jet, bullet cleaning, or drill rods.

In large-scale cooling water systems for heat exchangers, water treatment such as purification, addition of chemicals, and testing, is used to minimize fouling of the heat exchange equipment. Other water treatment is also used in steam systems for power plants, etc. to minimize fouling and corrosion of the heat exchange and other equipment.

A variety of companies have started using water borne oscillations technology to prevent biofouling. Without the use of chemicals, this type of technology has helped in providing a low-pressure drop in heat exchangers.

## ***In nature***

### **Humans**

The human nasal passages serve as a heat exchanger, which warms air being inhaled and cools air being exhaled. You can demonstrate its effectiveness by putting your hand in front of your face and exhaling, first through your nose and then through your mouth. Air exhaled through your nose will be substantially cooler.

In species that have external testes (such as humans), the artery to the testis is surrounded by a mesh of veins called the pampiniform plexus. This cools the blood heading to the testis, while reheating the returning blood.

### **Birds, fish, marine mammals**

"Countercurrent" heat exchangers occur naturally in the circulation system of fish, whales and other marine mammals. Arteries to the skin carrying warm blood are intertwined with veins from the skin carrying cold blood, causing the warm arterial blood to exchange heat with the cold venous blood. This reduces the overall heat loss in cold waters. Heat exchangers are also present in the tongue of baleen whales as large volumes of water flow through their mouths. Wading birds use a similar system to limit heat losses from their body through their legs into the water.

## ***In industry***

Heat exchangers are widely used in industry both for cooling and heating large scale industrial processes. The type and size of heat exchanger used can be tailored to suit a process depending on the type of fluid, its phase, temperature, density, viscosity, pressures, chemical composition and various other thermodynamic properties.

In many industrial processes there is waste of energy or a heat stream that is being exhausted, heat exchangers can be used to recover this heat and put it to use by heating a different stream in the process. This practice saves a lot of money in industry as the heat supplied to other streams from the heat exchangers would otherwise come from an external source which is more expensive and more harmful to the environment.

Heat exchangers are used in many industries, some of which include:

- Waste water treatment
- Refrigeration systems
- Wine-brewery industry
- Petroleum industry.

In the waste water treatment industry, heat exchangers play a vital role in maintaining optimal temperatures within anaerobic digesters so as to promote the growth of microbes which remove pollutants from the waste water. The common types of heat exchangers used in this application are the double pipe heat exchanger as well as the plate and frame heat exchanger.

### ***In aircraft***

In commercial aircraft heat exchangers are used to take heat from the engine's oil system to heat cold fuel. This improves fuel efficiency, as well as reduces the possibility of water entrapped in the fuel freezing in components.

In early 2008, a Boeing 777 flying as British Airways Flight 38 crashed just short of the runway. In an early-2009 Boeing-update sent to aircraft operators, the problem was identified as specific to the Rolls-Royce engine oil-fuel flow heat exchangers. Other heat exchangers, or Boeing 777 aircraft powered by GE or Pratt and Whitney engines, are not affected by the problem.

### ***A model of a simple heat exchanger***

A simple heat exchanger might be thought of as two straight pipes with fluid flow, which are thermally connected. Let the pipes be of equal length  $L$ , carrying fluids with heat capacity  $C_i$  (energy per unit mass per unit change in temperature) and let the mass flow rate of the fluids through the pipes be  $j_i$  (mass per unit time), where the subscript  $i$  applies to pipe 1 or pipe 2.

The temperature profiles for the pipes are  $T_1(x)$  and  $T_2(x)$  where  $x$  is the distance along the pipe. Assume a steady state, so that the temperature profiles are not functions of time. Assume also that the only transfer of heat from a small volume of fluid in one pipe is to the fluid element in the other pipe at the same position. There will be no transfer of heat along a pipe due to temperature differences in that pipe. By Newton's law of cooling the rate of change in energy of a small volume of fluid is proportional to the difference in temperatures between it and the corresponding element in the other pipe:

$$\begin{aligned}\frac{du_1}{dt} &= \gamma(T_2 - T_1) \\ \frac{du_2}{dt} &= \gamma(T_1 - T_2)\end{aligned}$$

where  $u_i(x)$  is the thermal energy per unit length and  $\gamma$  is the thermal connection constant per unit length between the two pipes. This change in internal energy results in a change in the temperature of the fluid element. The time rate of change for the fluid element being carried along by the flow is:

$$\frac{du_1}{dt} = J_1 \frac{dT_1}{dx}$$

$$\frac{du_2}{dt} = J_2 \frac{dT_2}{dx}$$

where  $J_i = C_j i$  is the "thermal mass flow rate". The differential equations governing the heat exchanger may now be written as:

$$J_1 \frac{\partial T_1}{\partial x} = \gamma(T_2 - T_1)$$

$$J_2 \frac{\partial T_2}{\partial x} = \gamma(T_1 - T_2).$$

Note that, since the system is in a steady state, there are no partial derivatives of temperature with respect to time, and since there is no heat transfer along the pipe, there are no second derivatives in  $x$  as is found in the heat equation. These two coupled first-order differential equations may be solved to yield:

$$T_1 = A - \frac{Bk_1}{k} e^{-kx}$$

$$T_2 = A + \frac{Bk_2}{k} e^{-kx}$$

where  $k_1 = \gamma / J_1$ ,  $k_2 = \gamma / J_2$ ,  $k = k_1 + k_2$  and  $A$  and  $B$  are two as yet undetermined constants of integration. Let  $T_{10}$  and  $T_{20}$  be the temperatures at  $x=0$  and let  $T_{1L}$  and  $T_{2L}$  be the temperatures at the end of the pipe at  $x=L$ . Define the average temperatures in each pipe as:

$$\bar{T}_1 = \frac{1}{L} \int_0^L T_1(x) dx$$

$$\bar{T}_2 = \frac{1}{L} \int_0^L T_2(x) dx.$$

Using the solutions above, these temperatures are:

$$T_{10} = A - \frac{Bk_1}{k} \quad T_{20} = A + \frac{Bk_2}{k}$$

$$T_{1L} = A - \frac{Bk_1}{k} e^{-kL} \quad T_{2L} = A + \frac{Bk_2}{k} e^{-kL}$$

$$\bar{T}_1 = A - \frac{Bk_1}{k^2 L} (1 - e^{-kL}) \quad \bar{T}_2 = A + \frac{Bk_2}{k^2 L} (1 - e^{-kL}).$$

Choosing any two of the above temperatures will allow the constants of integration to be eliminated, and that will allow the other four temperatures to be found. The total energy transferred is found by integrating the expressions for the time rate of change of internal energy per unit length:

$$\begin{aligned}\frac{dU_1}{dt} &= \int_0^L \frac{du_1}{dt} dx = J_1(T_{1L} - T_{10}) = \gamma L(\bar{T}_2 - \bar{T}_1) \\ \frac{dU_2}{dt} &= \int_0^L \frac{du_2}{dt} dx = J_2(T_{2L} - T_{20}) = \gamma L(\bar{T}_1 - \bar{T}_2).\end{aligned}$$

By the conservation of energy, the sum of the two energies is zero. The quantity  $\bar{T}_2 - \bar{T}_1$  is known as the "log mean temperature difference" and is a measure of the effectiveness of the heat exchanger in transferring heat energy.

## Chapter 5

# Blower Door



A **blower door** is a diagnostic tool designed to measure the airtightness of buildings, and to help locate air leakage sites. A blower door consists of a calibrated fan for measuring an airflow rate, and a pressure-sensing device to measure the air pressure created by the fan flow. The combination of pressure and fan-flow measurements are used to determine

the building airtightness. The airtightness of a building is useful knowledge when trying to increase energy conservation or decrease indoor air pollution, or control building pressures.

### ***Uses of blower-door testing***

Blower doors can be used in a variety of types of testing. These include (but are not limited to):

- Testing residential and commercial buildings for air tightness
- Testing buildings for compliance with standards for energy efficiency, such as the IECC and ASHRAE.
- Testing building envelopes and window frames for water tightness and rain penetration
- NFPA Clean Agent Retention testing (this type of testing is usually described as a *door fan test* rather than a blower door test)
- Testing forced air heating/cooling system Ductwork for leakage - both supply (vents) ducts and return ducts can be tested to determine if and how much they leak air.

### ***How blower-door tests work***

A basic blower-door system includes three components: a calibrated fan, a door-panel system, and a device to measure fan flow and building pressure. The blower-door fan is temporarily sealed into an exterior doorway using the door-panel system. The fan is used to blow air into or out of the building, which creates a small pressure difference between inside and outside. This pressure difference forces air through all holes and penetrations in the building enclosure. The tighter the building (e.g. fewer holes), the less air is needed from the blower door fan to create a change in building pressure.

Blower-door airtightness measurements are presented in a number of different formats, including but not limited to:

#### **Air flow**

CFM50 is defined as the air flow (in cubic feet per minute) needed to create a 50-pascal pressure change in the building envelope. CFM50 is one of the most basic measurements of airtightness. Air flow measurements are sometimes referenced to different building pressures such as 25 or 75 pascals.

#### **Air changes per hour at 50 pascals**

To compare relative airtightness of buildings, it is useful to normalize measurements for the size of the building. This allows easy comparison of various sized buildings to each other, or to program guidelines. One of the most common ways to normalize building airtightness is to calculate the number of times per hour the total volume of the enclosure

is changed, when the enclosure is subjected to a 50-pascal pressure difference. To calculate air changes per hour, the total volume of the enclosure is required in addition to the CFM50 measurement. It is also common to use the building enclosure surface area to normalize airtightness measurements.

A pressure of 50 Pa is equal to 0.2 inches (0.51 cm) of water column.

## **Leakage area**

Leakage area estimates are a useful way to visualize the cumulative size of all leaks or holes in the building enclosure. Estimated leakage areas can also be used in infiltration models to estimate natural infiltration rates (i.e. the air change rate under natural weather conditions). To accurately estimate leakage areas, it is best to conduct the blower-door test over a wide range of building pressures (e.g. 25 Pa to 50 Pa). There are a variety of standard calculation methods used to calculate leakage areas.

## **Leakage area per square area**

Leakage area estimates can also be normalized for the size of the enclosure being tested. For example, the LEED Green Building Rating System has set an airtightness standard for multifamily dwelling units of 1.25 square inches (8.1 cm<sup>2</sup>) of leakage area per 100 square feet (9.3 m<sup>2</sup>) of enclosure area, to control tobacco smoke between units. This is equal to 0.868 cm<sup>2</sup>/m<sup>2</sup>.

## ***NFPA Enclosure Integrity Testing***

NFPA enclosure integrity testing is a specialized type of testing that typically measures the tightness of rooms within buildings (though testing entire buildings require testing on occasion) that are protected by clean agent fire suppression systems. These types of enclosures are typically server rooms containing large amounts of computer and electronic hardware.

NFPA standards for equipment calibration are more rigorous than other types of testing, but any modern blower door equipment is sufficiently accurate to perform NFPA enclosure integrity testing.

The NFPA standard requires that the blower door operator be trained, but does not specify the nature or source of this training. There is no official NFPA training available for enclosure integrity testing methodology at this time.

An NFPA enclosure integrity test result is typically reported in the form of an *agent retention time* which represents the duration for which the room will retain the agent at sufficient concentration to suppress a fire. This retention time varies based on the leakage area of the room, the location of the leaks and the particular clean agent being used.

## ***American Manufacturers***

American Manufacturers are listed in alphabetical order.

- Energy Conservatory makers of the Minneapolis Blower Door for testing residential, multi-family, commercial and government buildings.
- Infiltec Air Leakage Control makers of the Infiltec blower door for residential and commercial use.
- Retrotec Inc. Makers of blower doors for residential, commercial, and fire integrity since 1980.

## Chapter 6

# Chilled Beam

A **chilled beam** is a type of convection HVAC system designed to heat or cool large buildings. Pipes of water are passed through a "beam" (a heat exchanger) suspended a short distance from the ceiling of a room. As the beam chills the air around it, the air becomes denser and falls to the floor. It is replaced by warmer air moving up from below, causing a constant flow of convection and cooling the room. Heating works in much the same fashion, similar to a steam radiator. There are two types of chilled beams. The passive type relies solely on convection, while the active type (also called an "induction diffuser") uses ducts to push ("induce") air toward the unit (increasing its heating and cooling capacity).

The chilled beam is distinguishable from the chilled ceiling. The chilled ceiling uses water flowing through pipes like a chilled beam does. But the pipes in a chilled ceiling lie behind metal ceiling plates, and the heated and cooled plates are the cause of convection and not the pipe unit itself. Chilled beams are about 85 percent more effective at convection than chilled ceilings.

### ***Physics of the chilled beam***

Water can carry significantly more energy air. Although 1 cubic foot (0.028 m<sup>3</sup>) of air has a capacity to hold heat of 37 joules per kelvin (JK), water has a heat capacity of 20,050 JK. A metal pipe of water just 1 inch (2.5 cm) in diameter can carry as much energy as an 18-by-18-inch (46 by 46 cm) metal duct of air. This means that chilled beam HVAC systems require much less energy to provide the same heating and cooling effect as a traditional air HVAC system.

Chilled beam cooling systems require water to be treated by heating and cooling systems. Generally, water in a passive chilled beam system is cooled to about 16 to 19 °C (61 to 66 °F). In active chilled beam heating systems, water temperature is usually 40 to 50 °C (104 to 122 °F). (Chilled beam heating systems usually cannot rely solely on convection,

however, and often require a fan-driven primary air circulation system to force the warmer air to the ground where most people sit and work.) There are effectiveness and cost differences between the two systems, however. Passive chilled beam systems can supply about 5.6 to 6.5 watts per foot (60 to 70 watts per metre) of cooling capacity. Active chilled beam systems are about twice as effective. In both cases, convection is so efficient that the ratio of incoming air to heated/cooled air can be as high as 6:1. However, studies of the energy cost-savings of active versus passive chilled beam systems remained inconclusive as of 2007, and appear to be highly dependent on the specific building.

The active chilled beam system employs fins to help heat and cool. Active chilled beam systems are effective to the point where outdoor air can be mixed with the indoor air without any traditional air conditioning (such as heating, cooling, humidifying, or dehumidifying), thus enabling a building to meet its "minimum outdoor air" air quality requirement.

### ***Advantages and disadvantages***

The primary advantage of the chilled beam system is its lower operating cost. For example, because the temperature of cooled water is higher than the temperature of cooled air but delivers the same cooling ability, the costs of the system are lower. Because cooling and heating of air are not longer linked to the delivery of air, buildings also save money by being able to run fewer air circulation fans and at lower speeds. One estimate places the amount of air handled at 25 to 50 percent less using chilled beam systems. By being able to target the delivery of clean outdoor air where it is needed (rather than injecting it into the entire system and heating or cooling it), there is a reduced need to treat large amounts of outdoor air (also saving money). In one case, the Genomic Science Building at the University of North Carolina at Chapel Hill lowered its HVAC costs by 20 percent with an active chilled beam system. This is a typical energy cost savings. Chilled beam systems also have some advantages in that they are almost noiseless, require little maintenance, and are highly efficient. Traditional fan-driven HVAC systems create somewhat higher air velocities, which some people find uncomfortable. Chilled beam HVAC systems also require less ceiling space than forced-air HVAC systems, which can lead to lower building heights and higher ceilings. Since they do not require high forced air flows, chilled beam systems also require reduced air distribution duct networks (which also helps to lower cost).

Chilled beam systems are not a panacea, however. Additional ductwork may be needed to meet minimum outdoor air requirements. Both types of chilled beam systems are less effective at heating than cooling, and supplementary heating systems are often needed. Chilled beam systems cannot be used alone in buildings where the ceilings are higher than 2.7 metres (8.9 ft), because the air will not properly circulate. A forced-air circulation system must be employed in such cases. If the water temperature is too low or humidity is high, condensation on the beam can occur—leading to a problem known as "internal rain." (In some cases, drier outside air can be mixed with the wetter inside air to reduced interior humidity levels while maintaining system performance.) Chilled beam

systems are not recommended for areas with high humidity (such as the theaters, gymnasiums, or cafeterias). Because they are less effective at cooling, passive chilled beam systems are generally ill-suited for semi-tropical and tropical climates. Hospitals are generally cannot use chilled beam systems because of restrictions on using recirculated air. Chilled beam systems are also known to cause noticeable air circulation which can make some people uncomfortable. (Passive air deflection devices can help disrupt these air patterns, alleviating the problem.) Some designers have found that enlarging the ducts around active chilled beam systems to increase air circulation causes echoes in working areas and amplifies the sound of water moving through the pipes to noticeable levels.

### ***Installation and adoption***

The most common active chilled beam design is in the form of a capital letter "T", upside down and suspended from the ceiling. They are generally 1 to 2 feet (0.30 to 0.61 m) wide, and require less than 1 foot (0.30 m) of overhead space. A typical 2-foot (0.61 m) wide chilled beam system generally weighs about 15 pounds (6.8 kg) per 1 foot (0.30 m) length of the beam. Chilled beams are generally installed so that the center of each beam is no more than 3 metres (9.8 ft) from the center of the next beam. Some designers dislike the beams, because they do not cover the entire ceiling and ducts, wiring, and other infrastructure can be seen. Some designers have installed one chilled beam system around the building perimeter (where temperature differences can be the greatest) and another in the interior of the building, to better control temperature throughout the structure. Higher system performance may be obtained by increasing the static pressure of the air in the building. The systems generally need little cleaning (vacuuming of dirt and dust from the fins need occur only every five years).

As of 2007, chilled beam HVAC systems were used more widely in Australia and Europe than the United States. Chilled beam HVAC systems have been used at London Heathrow Terminal 5 and Constitution Center (the largest private office building in Washington, D.C.). The system has also received prominent use at Harvard Business School, Wellesley College, and the American headquarters of the pharmaceutical company AstraZeneca.

The multiservice chilled beam is a relatively new form of the chilled beam. Developed in 1996, it incorporates computer and electrical wiring, lighting, motion-detection sensors, and sprinklers into the chilled beam unit. The multiservice chilled beam was first installed at the Barclaycard building in Northampton, England, but has since been used at the headquarters of Lloyd's Register (London), Airbus UK (Bristol), and the Greater London Authority; Riverside House (London); and the Empress State Building (London).

## Chapter 7

# Chiller



York International water-cooled chiller.

A **chiller** is a machine that removes heat from a liquid via a vapor-compression or absorption refrigeration cycle. This liquid can then be circulated through a heat exchanger to cool air or equipment as required.

## ***Use in air conditioning***

In air conditioning systems, chilled water is typically distributed to heat exchangers, or **coils**, in air handling units, or other type of terminal devices which cool the air in its respective space(s), and then the chilled water is re-circulated back to the chiller to be cooled again. These cooling coils transfer sensible heat and latent heat from the air to the chilled water, thus cooling and usually dehumidifying the air stream. A typical chiller for air conditioning applications is rated between 15 to 1500 tons (180,000 to 18,000,000 BTU/h or 53 to 5,300 kW) in cooling capacity. Chilled water temperatures can range from 35 to 45 degrees Fahrenheit (1.5 to 7 degrees Celsius), depending upon application requirements.

## ***Use in industry***

In industrial application, chilled water or other liquid from the chiller is pumped through process or laboratory equipment. Industrial chillers are used for controlled cooling of products, mechanisms and factory machinery in a wide range of industries. They are often used in the plastic industry in injection and blow molding, metal working cutting oils, welding equipment, die-casting and machine tooling, chemical processing, pharmaceutical formulation, food and beverage processing, paper and cement processing, vacuum systems, X-ray diffraction, power supplies and power generation stations, analytical equipment, semiconductors, compressed air and gas cooling. They are also used to cool high-heat specialized items such as MRI machines and lasers, and in hospitals, hotels and campuses.

The chillers for industrial applications can be centralized, where each chiller serves multiple cooling needs, or decentralized where each application or machine has its own chiller. Each approach has its advantages. It is also possible to have a combination of both centralized and decentralized chillers, especially if the cooling requirements are the same for some applications or points of use, but not all.

Decentralized chillers are usually small in size (cooling capacity), usually from 0.2 tons to 10 tons. Centralized chillers generally have capacities ranging from ten tons to hundreds or thousands of tons.

Chilled water is used to cool and dehumidify air in mid- to large-size commercial, industrial, and institutional (CII) facilities. Water chillers can be water-cooled, air-cooled, or evaporatively cooled. Water-cooled chillers incorporate the use of cooling towers which improve the chillers' thermodynamic effectiveness as compared to air-cooled chillers. This is due to heat rejection at or near the air's wet-bulb temperature rather than the higher, sometimes much higher, dry-bulb temperature. Evaporatively cooled chillers offer higher efficiencies than air-cooled chillers but lower than water-cooled chillers.

Water-cooled chillers are typically intended for indoor installation and operation, and are cooled by a separate condenser water loop and connected to outdoor cooling towers to expel heat to the atmosphere.

Air-cooled and Evaporatively cooled chillers are intended for outdoor installation and operation. Air-cooled machines are directly cooled by ambient air being mechanically circulated directly through the machine's condenser coil to expel heat to the atmosphere. Evaporatively cooled machines are similar, except they implement a mist of water over the condenser coil to aid in condenser cooling, making the machine more efficient than a traditional air-cooled machine. No remote cooling tower is typically required with either of these types of packaged air-cooled or evaporatively cooled chillers.

Where available, cold water readily available in nearby water bodies might be used directly for cooling, place or supplement cooling towers. The Deep Lake Water Cooling System in Toronto, Canada, is an example. It dispensed with the need for cooling towers, with a significant cut in carbon emissions and energy consumption. It uses cold lake water to cool the chillers, which in turn are used to cool city buildings via a district cooling system. The return water is used to warm the city's drinking water supply which is desirable in this cold climate. Whenever a chiller's heat rejection can be used for a productive purpose, in addition to the cooling function, very high thermal effectiveness is possible.

### ***Vapor-Compression chiller technology***

There are basically four different types of compressors used in vapor compression chillers: Reciprocating compression, scroll compression, screw-driven compression, and centrifugal compression are all mechanical machines that can be powered by electric motors, steam, or gas turbines. They produce their cooling effect via the "reverse-Rankine" cycle, also known as 'vapor-compression'. With evaporative cooling heat rejection, their coefficients-of-performance (COPs) are very high; typically 4.0 or more.

In recent years, application of Variable Speed Drive (VSD) technology has increased efficiencies of vapor compression chillers. The first VSD was applied to centrifugal compressor chillers in the late 1970s and has become the norm as the cost of energy has increased. Now, VSDs are being applied to rotary screw and scroll technology compressors.

### ***How adsorption technology works***

Adsorption chillers are driven by hot water. This hot water may come from any number of industrial sources including waste heat from industrial processes, prime heat from solar thermal installations or from the exhaust or water jacket heat of a piston engine or turbine.

The principle of adsorption is based on the interaction of gases and solids. With adsorption chilling, the molecular interaction between the solid and the gas allows the gas to be adsorbed into the solid. The adsorption chamber of the chiller is filled with solid material, silica gel, eliminating the need for moving parts and eliminating the noise associated with those moving parts. The silica gel creates an extremely low humidity

condition that causes the water refrigerant to evaporate at a low temperature. As the water evaporates in the evaporator, it cools the chilled water.

The use of silica gel desiccant keeps the maintenance costs and operating costs of adsorption chillers low.

### ***How absorption technology works***

Absorption chillers' thermodynamic cycle are driven by heat source; this heat is usually delivered to the chiller via steam, hot water, or combustion. Compared to electrically powered chillers, they have very low electrical power requirements - very rarely above 15 kW combined consumption for both the solution pump and the refrigerant pump. However, their heat input requirements are large, and their COPs are often 0.5 (single-effect) to 1.0 (double-effect). For the same tonnage capacity, they require much larger cooling towers than vapor-compression chillers. However, absorption chillers, from an energy-efficiency point-of-view, excel where cheap, high grade heat or waste heat is readily available. In extremely sunny climates, solar energy has been used to operate absorption chillers.

The single effect of water-cooled machines and instruments. The water flows from the chiller to the application's point of use and back.

If the water temperature differs in the tank.

One of the newer developments in industrial water chillers is the use of water cooling instead of air cooling. In this case the condenser does not cool the hot refrigerant with ambient air, but uses water cooled by a cooling tower. This development allows a reduction in energy requirements by more than 15% and also allows a significant reduction in the size of the chiller due to the small surface area of the water based condenser and the absence of fans. Additionally, the absence of fans allows for significantly reduced noise levels.

Most industrial chillers use refrigeration as the media for cooling, but some rely on simpler techniques such as air or water flowing over coils containing the coolant to regulate temperature. Water is the most commonly used coolant within process chillers, although coolant mixtures (mostly water with a coolant additive to enhance heat dissipation) are frequently employed.

### ***Industrial chiller selection***

Important specifications to consider when searching for industrial chillers include the total life cycle cost, the power source, chiller IP rating, chiller cooling capacity, evaporator capacity, evaporator material, evaporator type, condenser material, condenser capacity, ambient temperature, motor fan type, noise level, internal piping materials, number of compressors, type of compressor, number of fridge circuits, coolant requirements, fluid discharge temperature, and COP (the ratio between the cooling

capacity in RT to the energy consumed by the whole chiller in KW). For medium to large chillers this should range from 3.5-7.0 with higher values meaning higher efficiency. Chiller efficiency is often specified in kilowatts per refrigeration ton (kW/RT).

Process pump specifications that are important to consider include the process flow, process pressure, pump material, elastomer and mechanical shaft seal material, motor voltage, motor electrical class, motor IP rating and pump rating. If the cold water temperature is lower than  $-5^{\circ}\text{C}$ , then a special pump needs to be used to be able to pump the high concentrations of ethylene glycol. Other important specifications include the internal water tank size and materials and full load current.

Control panel features that should be considered when selecting between industrial chillers include the local control panel, remote control panel, fault indicators, temperature indicators, and pressure indicators.

Additional features include emergency alarms, hot gas bypass, city water switchover, and casters.

## ***Refrigerants***

A vapor-compression chiller uses a refrigerant internally as its working fluid. Many refrigerants options are available; when selecting a chiller, the application cooling temperature requirements and refrigerant's cooling characteristics need to be matched. Important parameters to consider are the operating temperatures and pressures.

There are several environmental factors that concern refrigerants, and also affect the future availability for chiller applications. This is a key consideration in intermittent applications where a large chiller may last for 25 years or more. Ozone depletion potential (ODP) and global warming potential (GWP) of the refrigerant need to be considered. ODP and GWP data for some of the more common vapor-compression refrigerants:

<b>Refrigerant</b>	<b>ODP</b>	<b>GWP</b>
R134a	0	1300
R123	0.012	76
R22	0.05	1700
R290 (propane)	0	3
R401a	0.027	970
R404a	0	3260
R407a	0	???
R407c	0	1525
R408a	0.016	3020

R409a	0.039	1290
R410a	0	1725
R500	0.7	???
R502	0.18	5600
R717 (ammonia)	0	0

## Chapter 8

# Air Conditioning

**Air conditioning** is the removal of heat from indoor air for thermal comfort.

In another sense, the term can refer to any form of cooling, heating, ventilation, or disinfection that modifies the condition of air. An air conditioner (often referred to as AC or air con.) is an appliance, system, or machine designed to stabilise the air temperature and humidity within an area (used for cooling as well as heating depending on the air properties at a given time), typically using a refrigeration cycle but sometimes using evaporation, commonly for comfort cooling in buildings and motor vehicles.

The concept of air conditioning is known to have been applied in Ancient Rome, where aqueduct water was circulated through the walls of certain houses to cool them. Similar techniques in medieval Persia involved the use of cisterns and wind towers to cool buildings during the hot season. Modern air conditioning emerged from advances in chemistry during the 19th century, and the first large-scale electrical air conditioning was invented and used in 1902 by Willis Haviland Carrier.

### **History**

The 2nd century Chinese inventor Ding Huane (fl. 180) of the Han Dynasty invented a rotary fan for air conditioning, with seven wheels 3 m (9.8 ft) in diameter and manually powered. In 747, Emperor Xuanzong (r. 712–762) of the Tang Dynasty (618–907) had the Cool Hall (*Liang Tian*) built in the imperial palace, which the *Tang Yulin* describes as having water-powered fan wheels for air conditioning as well as rising jet streams of water from fountains. During the subsequent Song Dynasty (960–1279), written sources mentioned the air conditioning rotary fan as even more widely used.

In the 17th century Cornelius Drebbel demonstrated "turning Summer into Winter" for James I of England by adding salt to water.

In 1758, Benjamin Franklin and John Hadley, a chemistry professor at Cambridge University, conducted an experiment to explore the principle of evaporation as a means to rapidly cool an object. Franklin and Hadley confirmed that evaporation of highly volatile liquids such as alcohol and ether could be used to drive down the temperature of an object past the freezing point of water. They conducted their experiment with the bulb of a mercury thermometer as their object and with a bellows used to "quicken" the evaporation; they lowered the temperature of the thermometer bulb down to 7°F while the ambient temperature was 65°F. Franklin noted that soon after they passed the freezing point of water (32°F) a thin film of ice formed on the surface of the thermometer's bulb and that the ice mass was about a quarter inch thick when they stopped the experiment upon reaching 7°F. Franklin concluded, "From this experiment, one may see the possibility of freezing a man to death on a warm summer's day".

In 1820, British scientist and inventor Michael Faraday discovered that compressing and liquefying ammonia could chill air when the liquefied ammonia was allowed to evaporate. In 1842, Florida physician John Gorrie used compressor technology to create ice, which he used to cool air for his patients in his hospital in Apalachicola, Florida. He hoped eventually to use his ice-making machine to regulate the temperature of buildings. He even envisioned centralized air conditioning that could cool entire cities. Though his prototype leaked and performed irregularly, Gorrie was granted a patent in 1851 for his ice-making machine. His hopes for its success vanished soon afterwards when his chief financial backer died; Gorrie did not get the money he needed to develop the machine. According to his biographer, Vivian M. Sherlock, he blamed the "Ice King", Frederic Tudor, for his failure, suspecting that Tudor had launched a smear campaign against his invention. Dr. Gorrie died impoverished in 1855 and the idea of air conditioning faded away for 50 years.

In 1902, the first modern electrical air conditioning unit was invented by Willis Haviland Carrier in Buffalo, New York. After graduating from Cornell University, Carrier, a native of Angola, New York, found a job at the Buffalo Forge Company. While there, Carrier began experimentation with air conditioning as a way to solve an application problem for the Sackett-Wilhelms Lithographing and Publishing Company in Brooklyn, New York, and the first "air conditioner", designed and built in Buffalo by Carrier, began working on 17 July 1902.

Designed to improve manufacturing process control in a printing plant, Carrier's invention controlled not only temperature but also humidity. Carrier used his knowledge of the heating of objects with steam and reversed the process. Instead of sending air through hot coils, he sent it through cold coils (ones filled with cold water). The air blowing over the cold coils cooled the air, and one could thereby control the amount of moisture the colder air could hold. In turn, the humidity in the room could be controlled. The low heat and humidity were to help maintain consistent paper dimensions and ink alignment. Later, Carrier's technology was applied to increase productivity in the workplace, and The Carrier Air Conditioning Company of America was formed to meet rising demand. Over time, air conditioning came to be used to improve comfort in homes and automobiles as well. Residential sales expanded dramatically in the 1950s.

In 1906, Stuart W. Cramer of Charlotte, North Carolina was exploring ways to add moisture to the air in his textile mill. Cramer coined the term "air conditioning", using it in a patent claim he filed that year as an analogue to "water conditioning", then a well-known process for making textiles easier to process. He combined moisture with ventilation to "condition" and change the air in the factories, controlling the humidity so necessary in textile plants. Willis Carrier adopted the term and incorporated it into the name of his company. This evaporation of water in air, to provide a cooling effect, is now known as evaporative cooling.

The first air conditioners and refrigerators employed toxic or flammable gases, such as ammonia, methyl chloride, and propane, that could result in fatal accidents when they leaked. Thomas Midgley, Jr. created the first chlorofluorocarbon gas, Freon, in 1928.

*Freon* is a trademark name owned by DuPont for any Chlorofluorocarbon (CFC), Hydrogenated CFC (HCFC), or Hydrofluorocarbon (HFC) refrigerant, the name of each including a number indicating molecular composition (R-11, R-12, R-22, R-134A). The blend most used in direct-expansion home and building comfort cooling is an HCFC known as R-22. It is to be phased out for use in new equipment by 2010 and completely discontinued by 2020.

R-12 was the most common blend used in automobiles in the US until 1994 when most changed to R-134A. R-11 and R-12 are no longer manufactured in the US for this type of application, the only source for air conditioning purchase being the cleaned and purified gas recovered from other air conditioner systems. Several non-ozone depleting refrigerants have been developed as alternatives, including R-410A, invented by Honeywell (formerly AlliedSignal) in Buffalo, and sold under the Genetron (R) AZ-20 name. It was first commercially used by Carrier under the brand name *Puron*.

Innovation in air conditioning technologies continues, with much recent emphasis placed on energy efficiency, and on improving indoor air quality. Reducing climate change impact is an important area of innovation, because in addition to greenhouse gas emissions associated with energy use, CFCs, HCFCs and HFCs are, themselves, potent greenhouse gases when leaked to the atmosphere. For example, R-22 (also known as HCFC-22) has a global warming potential about 1,800 times higher than CO<sub>2</sub>. As an alternative to conventional refrigerants, natural alternatives like CO<sub>2</sub> (R-744) have been proposed.

## Air conditioning applications



An air conditioner.

Air conditioning engineers broadly divide air conditioning applications into *comfort* and *process*.

*Comfort applications* aim to provide a building indoor environment that remains relatively constant in a range preferred by humans despite changes in external weather conditions or in internal heat loads.

Air conditioning makes deep plan buildings feasible, for otherwise they would have to be built narrower or with light wells so that inner spaces receive sufficient outdoor air via natural ventilation. Air conditioning also allows buildings to be taller since wind speed increases significantly with altitude making natural ventilation impractical for very tall buildings. Comfort applications for various building types are quite different and may be categorized as

- *Low-Rise Residential* buildings, including single family houses, duplexes, and small apartment buildings
- *High-Rise Residential* buildings, such as tall dormitories and apartment blocks
- *Commercial* buildings, which are built for commerce, including offices, malls, shopping centers, restaurants, etc.
- *Institutional* buildings, which includes hospitals, governmental, academic, and so on.
- *Industrial* spaces where thermal comfort of workers is desired.

- *Sports Stadiums* - recently, stadiums have been built with air conditioning to allow competition to take place in summer, such as University of Phoenix Stadium and in Qatar for the 2022 FIFA World Cup.

In addition to buildings, air conditioning can be used for many types of transportation — motor-cars and other land vehicles, trains, ships, aircraft, and spacecraft.

*Process applications* aim to provide a suitable environment for a process being carried out, regardless of internal heat and humidity loads and external weather conditions. Although often in the comfort range, it is the needs of the process that determine conditions, not human preference. Process applications include these:

- Hospital operating theatres, in which air is filtered to high levels to reduce infection risk and the humidity controlled to limit patient dehydration. Although temperatures are often in the comfort range, some specialist procedures such as open heart surgery require low temperatures (about 18 °C, 64 °F) and others such as neonatal relatively high temperatures (about 28 °C, 82 °F).
- Cleanrooms for the production of integrated circuits, pharmaceuticals, and the like, in which very high levels of air cleanliness and control of temperature and humidity are required for the success of the process.
- Facilities for breeding laboratory animals. Since many animals normally only reproduce in spring, holding them in rooms at which conditions mirror spring all year can cause them to reproduce year-round.
- Aircraft air conditioning. Although nominally aimed at providing comfort for passengers and cooling of equipment, aircraft air conditioning presents a special challenge because of the changing density associated with changes in altitude, humidity and temperature of the outside air.
- Data centers
- Textile manufacturing
- Physical testing facilities
- Plants and farm growing areas
- Nuclear power facilities
- Chemical and biological laboratories
- Mining
- Industrial environments
- Food cooking and processing areas

In both comfort and process applications, the objective may be to not only control temperature, but also humidity, air quality and air movement from space to space.

## ***Humidity control***



Air conditioning units outside a classroom building at the University of North Carolina in Chapel Hill, North Carolina

Refrigeration air conditioning equipment usually reduces the humidity of the air processed by the system. The relatively cold (below the dewpoint) evaporator coil condenses water vapor from the processed air (much like an ice-cold drink will condense water on the outside of a glass), sending the water to a drain and removing water vapor from the cooled space and lowering the relative humidity. Since humans perspire to provide natural cooling by the evaporation of perspiration from the skin, drier air (up to a point) improves the comfort provided. The comfort air conditioner is designed to create a 40% to 60% relative humidity in the occupied space. In food retailing establishments, large open chiller cabinets act as highly effective air dehumidifying units.

A specific type of air conditioner that is used only for dehumidifying is called a dehumidifier. A dehumidifier is different from a regular air conditioner in that both the evaporator and condenser coils are placed in the same air path, and the entire unit is placed in the environment that is intended to be conditioned (in this case dehumidified), rather than requiring the condenser coil to be outdoors. Having the condenser coil in the same air path as the evaporator coil produces warm, dehumidified air. The evaporator (cold) coil is placed first in the air path, dehumidifying the air exactly as a regular air conditioner does. The air next passes over the condenser coil re-warming the now dehumidified air. Note that the terms "condenser coil" and "evaporator coil" do not refer to the behavior of water in the air as it passes over each coil; instead they refer to the

phases of the refrigeration cycle. Having the condenser coil in the main air path rather than in a separate, outdoor air path (as in a regular air conditioner) results in two consequences—the output air is warm rather than cold, and the unit is able to be placed anywhere in the environment to be conditioned, without a need to have the condenser outdoors.

Unlike a regular air conditioner, a dehumidifier will actually heat a room just as an electric heater that draws the same amount of power (watts) as the dehumidifier. A regular air conditioner transfers energy out of the room by means of the condenser coil, which is outside the room (outdoors). This is a thermodynamic system where the room serves as the system and energy is transferred out of the system. Conversely with a dehumidifier, no energy is transferred out of the thermodynamic system (room) because the air conditioning unit (dehumidifier) is entirely inside the room. Therefore all of the power consumed by the dehumidifier is energy that is input into the thermodynamic system (the room), and remains in the room (as heat). In addition, if the condensed water has been removed from the room, the amount of heat needed to boil that water has been added to the room. This is the inverse of adding water to the room with an evaporative cooler.

Dehumidifiers are commonly used in cold, damp climates to prevent mold growth indoors, especially in basements. They are also sometimes used in hot, humid climates for comfort because they reduce the humidity which causes discomfort (just as a regular air conditioner, but without cooling the room). They are also used to protect sensitive equipment from the adverse effects of excessive humidity in tropical countries.

The engineering of physical and thermodynamic properties of gas-vapor mixtures is named Psychrometrics.

### ***Health issues***

Air-conditioning system can promote the growth and spread of microorganisms, such as *Legionella pneumophila*, the infectious agent responsible for Legionnaires' disease, or thermophilic actinomycetes, but as long as the air conditioner is kept clean these health hazards can be avoided. Conversely, air conditioning, including filtration, humidification, cooling, disinfection, etc., can be used to provide a clean, safe, hypoallergenic atmosphere in hospital operating rooms and other environments where an appropriate atmosphere is critical to patient safety and well-being. Air conditioning can have a positive effect on sufferers of allergies and asthma.

In serious heat waves, air conditioning can save the lives of the elderly. Some local authorities have even set up public cooling centers for people without home air conditioning.

## ***Energy use***

In a thermodynamically closed system, any energy input into the system that is being maintained at a set temperature (which is a standard mode of operation for modern air conditioners) requires that the energy removal rate from the air conditioner increases. This increase has the effect that for each unit of energy input into the system (say to power a light bulb in the closed system) this requires the air conditioner to remove that energy. In order to do that the air conditioner must increase its consumption by the inverse of its efficiency times the input of energy. As an example, presume that inside the closed system a 100 watt light bulb is activated, and the air conditioner has an efficiency of 200%. The air conditioner's energy consumption will increase by 50 W to compensate for this, thus making the 100 W light bulb use a total of 150 W of energy.

It is typical for air conditioners to operate at "efficiencies" of significantly greater than 100%. However it may be noted that the input (electrical) energy is of higher thermodynamic quality than the output which is basically thermal energy (heat dissipated).

## ***Automobile air conditioners***

Air conditioning systems are designed to allow the driver and or passengers to feel more comfortable during uncomfortably warm, humid, or hot trips in a vehicle. Cars in hot climates often are fitted with air conditioning. There has been much debate and discussion on what the usage of an air conditioner does to the fuel efficiency of a vehicle. Factors such as wind resistance, aerodynamics and engine power and weight have to be factored into finding the true variance between using the air conditioning system and not using it when figuring out difference in actual gas mileage. Other factors on the impact on the engine and an overall engine heat increase can have an impact on the cooling system of the vehicle.



1953 Chrysler Imperial with factory trunk mounted "Airtemp"

The first air conditioning for cars, was in 1933 when a company in New York city offered installation of air conditioning for cars. Most of their customers were limousine and high end cars for the wealthy.

The Packard Motor Car Company was the first automobile manufacturer to build air conditioners into its cars, beginning in 1939. These air conditioners were originally optional, and could be installed for an extra US\$274 (about US\$4,050 in 2007 dollars). The system took up half of the entire trunk space, was not very efficient, and had no thermostat or independent shut-off mechanism. The option was discontinued after 1941.

In 1954, the Nash Ambassador was the first American automobile to boast front-end, fully-integrated heating, ventilating, and air-conditioning system. The Nash-Kelvinator corporation used its experience in refrigeration to introduce the automobile industry's first compact and affordable, single-unit heating and air conditioning system optional for its 1954 Nash models. This was the first system for the mass market with controls on the dash and an electric clutch. Marketed under the name of "All-Weather Eye", the Nash system was "a good and remarkably inexpensive" system. Entirely incorporated within the engine bay, the combined heating and cooling system had cold air for passengers enter through dash-mounted vents. Nash's exclusive "remarkable advance" was not only the "sophisticated" unified system, but also its \$345 price that beat all other systems.

Most competing systems used a separate heating system and an engine-mounted compressor, driven off of the crankshaft of the engine via a belt, with an evaporator in the car's trunk to deliver cold air through the rear parcel shelf and overhead vents. General Motors made a front mounted air conditioning system optional in 1954 on Pontiacs with a straight-eight engine that added separate controls and air distribution. The alternative layout pioneered by Nash "became established practice and continues to form the basis of the modern and more sophisticated automatic climate control systems."

The innovation was adopted quickly, and by 1960 about 20% of all cars in the U.S. had air-conditioning, with the percentage increasing to 80% in the warm areas of the Southwest. American Motors made air conditioning standard equipment on all AMC Ambassadors starting with the 1968 model year, a first in the mass market with a base price starting at \$2,671. By 1969, 54% of the domestic automobiles were equipped with air conditioning, with the system needed not only for passenger comfort, but also to increase the car's resale value.

### ***Portable air conditioners***

A portable air conditioner is one on wheels that can be easily transported inside a home or office. They are currently available with capacities of about 6,000-60,000 BTU/h (1,800-18,000 W output) and with and without electric resistance heaters. Portable air conditioners are either evaporative or refrigerative.

Portable refrigerative air conditioners come in two forms, split and hose. These compressor-based refrigerant systems are air-cooled, meaning they use air to exchange heat, in the same way as a car or typical household air conditioner. Such a system dehumidifies the air as it cools it. It collects water condensed from the cooled air, and produces hot air which must be vented outside the cooled area; doing so transfers heat from the air in the cooled area to the outside air.

A portable split system has an indoor unit on wheels connected to an outdoor unit via flexible pipes, similar to a permanently fixed installed unit.

Hose systems, which can be **air-to-air** or **monoblock**, are vented to the outside via air ducts. The **monoblock** type collects the water in a bucket or tray and stops when full. The **air-to-air** type re-evaporates the water and discharges it through the ducted hose, and can run continuously.

A single-duct unit draws air out of the room to cool its condenser, and then vents it outside. This air is replaced by hot air from outside or other rooms, thus reducing efficiency. Modern units might have a COP (Coefficient Of Performance, sometimes called "efficiency") of approximately 3 i.e., 1 kW of electricity will produce 3 kW of cooling. A dual-duct unit draws air from outside to cool its condenser instead of from inside the room, and thus is more efficient than most single-duct units.

Evaporative air coolers, sometimes called "swamp air conditioners", do not have a compressor or condenser. Liquid water is evaporated on the cooling fins, releasing the vapour into the cooled area. Evaporating water absorbs a significant amount of heat, the latent heat of vaporisation, cooling the air — humans and other animals use the same mechanism to cool themselves by sweating. Disadvantages are that unless ambient humidity is low (as in a dry climate) cooling is limited and the cooled air is very humid and can feel clammy. They have the advantage of needing no hoses to vent heat outside the cooled area, making them truly portable; and they are very cheap to install and use less energy than refrigerative air conditioners.

## ***Heat pumps***

*Heat pump* is a term for a type of air conditioner in which the refrigeration cycle is able to be reversed, producing heat instead of cold in the indoor environment. They are also commonly referred to, and marketed as, a reverse cycle air conditioner. Using an air conditioner in this way to produce heat is significantly more efficient than electric resistance heating. Some home-owners elect to have a heat pump system installed, which is actually simply a central air conditioner with heat pump functionality (the refrigeration cycle is reversed in the winter). When the heat pump is enabled, the indoor evaporator coil switches roles and becomes the condenser coil, producing heat. The outdoor condenser unit also switches roles to serve as the evaporator, and produces cold air (colder than the ambient outdoor air).

Heat pumps are more popular in milder winter climates where the temperature is frequently in the range of 40-55°F (4-13°C), because heat pumps become inefficient in more extreme cold. This is due to the problem of the outdoor unit's coil forming ice, which blocks air flow over the coil. To compensate for this, the heat pump system must temporarily switch back into the regular air conditioning mode to switch the outdoor evaporator coil *back* to being the condenser coil so that it can heat up and de-ice. A heat pump system therefore will have a form of electric resistance heating in the indoor air path that is activated only in this mode in order to compensate for the temporary air conditioning, which would otherwise generate undesirable cold air in the winter. The icing problem becomes much more prevalent with lower outdoor temperatures, so heat pumps are commonly installed in tandem with a more conventional form of heating, such as a natural gas or oil furnace, which is used instead of the heat pump during harsher winter temperatures. In this case, the heat pump is used efficiently during the milder temperatures, and the system is switched to the conventional heat source when the outdoor temperature is lower.

Absorption heat pumps are actually a kind of air-source heat pumps, but they do not depend on electricity to power them. Instead, gas, solar power, or heated water is used as a main power source. Additionally, refrigerant isn't used at all in the process. To extract heat, an absorption pump absorbs ammonia into water. Next, the water and ammonia mixture is pressurized to induce boiling, and the ammonia is boiled off.

Some more expensive window air conditioning units have the heat pump function. However, a window unit that has a "heat" selection is not necessarily a heat pump because some units use electric resistance heat when heating is desired. A unit that has true heat pump functionality will be indicated in its literature by the term "heat pump".

### ***Professional bodies***

#### **American Society of Heating, Refrigerating, and Air-Conditioning Engineers**

ASHRAE (American Society of Heating, Refrigerating, and Air-Conditioning Engineers) is an organization devoted to the advancement of indoor-environment-control technology in the heating, ventilation, and air conditioning (HVAC) industry. ASHRAE was founded in 1894 to serve as a source of technical standards and guidelines. Since that time, it has grown into an international society that offers educational information, courses, seminars, career guidance, and publications. The organization also promotes a code of ethics for HVAC professionals and provides for liaison with the general public. Its headquarters are in Atlanta, GA.

#### **Australian Institute of Refrigeration Air Conditioning and Heating**

The Australian Institute of Refrigeration Air Conditioning and Heating (AIRAH) was founded in 1920 and currently has around 10,000 members. AIRAH is the official Australian secretariat of the International Institute of Refrigeration (IIR) and collaborates closely with the American Society of Heating, Refrigeration and Air Conditioning Engineers (ASHRAE).

#### **Air Conditioning and Mechanical Contractors Association of Australia**

The Air Conditioning and Mechanical Contractors Association of Australia (AMCA) is a nation wide industry association dedicated to represent and service the air conditioning and mechanical services industry in Australia. Members of AMCA design, install and provide ongoing service of air conditioning and mechanical ventilation systems.

#### **Air Conditioning Contractors of America (ACCA)**

The ACCA is a large organization of American HVACR professionals. They have over four thousand members and have individual charters in each state .

#### **Institute of Refrigeration (IOR)**

The IOR was founded in 1899 and represents professional refrigeration and air conditioning engineers in the United Kingdom

## **Refrigeration Service Engineers Society (RSES)**

The Refrigeration Service Engineers Society is a public non profit educational organization devoted to furthering the education and career growth of those who install, troubleshoot and repair air conditioning, ventilation, heating and refrigeration equipment. RSES maintains local chapters in most large cities and states.

## Chapter 9

# Ventilation (Architecture)

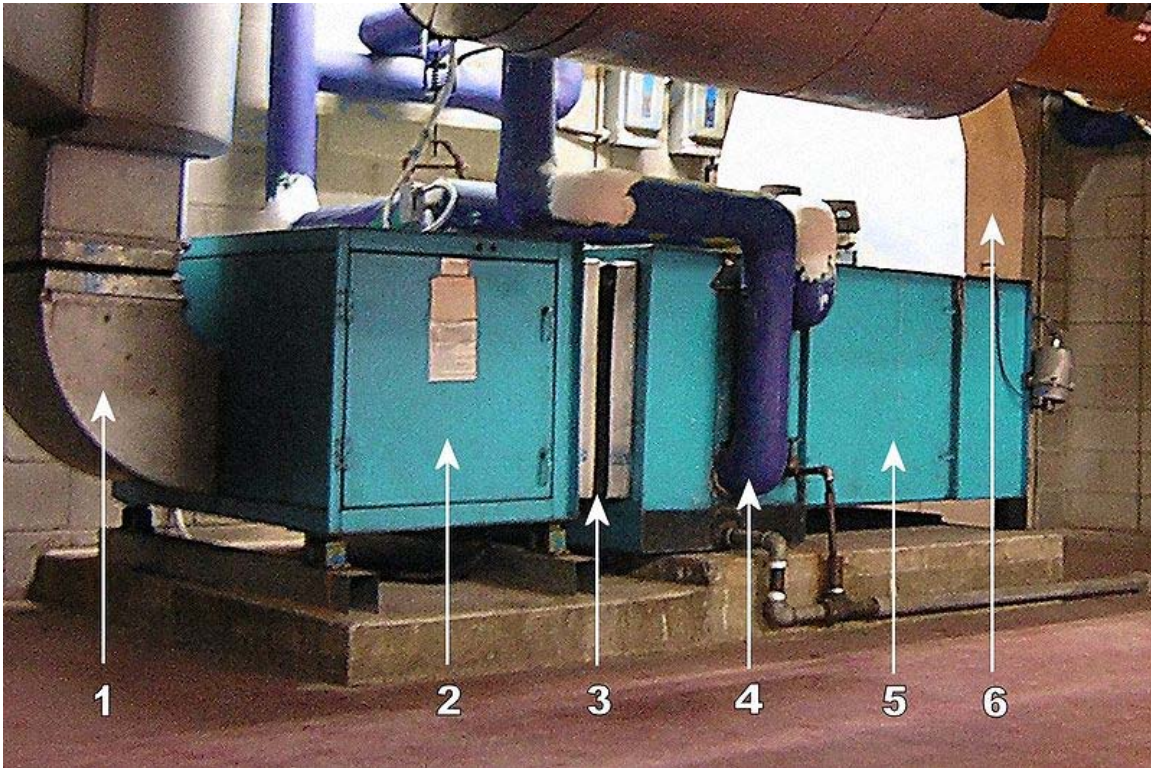

An air handling unit is used for the heating and cooling of air in a central location.

**Ventilating** (the *V* in HVAC) is the process of "changing" or replacing air in any space to provide high indoor air quality (i.e. to control temperature, replenish oxygen, or remove moisture, odors, smoke, heat, dust, airborne bacteria, and carbon dioxide). Ventilation is used to remove unpleasant smells and excessive moisture, introduce outside air, to keep interior building air circulating, and to prevent stagnation of the interior air.

Ventilation includes both the exchange of air to the outside as well as circulation of air within the building. It is one of the most important factors for maintaining acceptable indoor air quality in buildings. Methods for ventilating a building may be divided into *mechanical/forced* and *natural* types.

**"Mechanical" or "forced" ventilation** is used to control indoor air quality. Excess humidity, odors, and contaminants can often be controlled via dilution or replacement with outside air. However, in humid climates much energy is required to remove excess moisture from ventilation air.

Kitchens and bathrooms typically have mechanical exhaust to control odors and sometimes humidity. Factors in the design of such systems include the flow rate (which is a function of the fan speed and exhaust vent size) and noise level. If ducting for the fans traverse unheated space (e.g., an attic), the ducting should be insulated as well to prevent condensation on the ducting. Direct drive fans are available for many applications, and can reduce maintenance needs.

Ceiling fans and table/floor fans circulate air within a room for the purpose of reducing the perceived temperature because of evaporation of perspiration on the skin of the occupants. Because hot air rises, ceiling fans may be used to keep a room warmer in the winter by circulating the warm stratified air from the ceiling to the floor. Ceiling fans do not provide ventilation as defined as the introduction of outside air.

**Natural ventilation** is the ventilation of a building with outside air without the use of a fan or other mechanical system. It can be achieved with openable windows or trickle vents when the spaces to ventilate are small and the architecture permits. In more complex systems warm air in the building can be allowed to rise and flow out upper openings to the outside (stack effect) thus forcing cool outside air to be drawn into the building naturally through openings in the lower areas. These systems use very little energy but care must be taken to ensure the occupants' comfort. In warm or humid months, in many climates, maintaining thermal comfort solely via natural ventilation may not be possible so conventional air conditioning systems are used as backups. Air-side economizers perform the same function as natural ventilation, but use mechanical systems' fans, ducts, dampers, and control systems to introduce and distribute cool outdoor air when appropriate.

## ***Definition***

**Ventilation** is the intentional movement of air from outside a building to the inside. **Ventilation air**, as defined in ASHRAE Standard 62.1 and the *ASHRAE Handbook*, is that air used for providing acceptable indoor air quality. It mustn't be confused with *vents* or *flues*; which mean the exhausts of clothes dryers, and combustion equipment such as water heaters, boilers, fireplaces, and wood stoves. The vents or flues carry the products of combustion which have to be expelled from the building in a way which does not cause harm to the occupants of the building. Movement of air between indoor spaces, and not the outside, is called **transfer air**.

## An example of closed ventilation

In commercial, industrial, and institutional (CII) buildings, and modern jet aircraft, return air is often recirculated to the air handling unit. A portion of the supply air is normally exfiltrated through the building envelope or exhausted from the building (e.g., bathroom or kitchen exhaust) and is replaced by outside air introduced into the return air stream. The rate of ventilation air required, most often provided by this mechanically-induced outside air, is often determined from *ASHRAE Standard 62.1* for CII buildings, or *62.2* for low-rise residential buildings, or similar standards.

## Necessity

When people or animals are present in buildings, ventilation air is necessary to dilute odors and limit the concentration of carbon dioxide and airborne pollutants such as dust, smoke and volatile organic compounds (VOCs). Ventilation air is often delivered to spaces by mechanical systems which may also heat, cool, humidify and dehumidify the space. Air movement into buildings can occur due to uncontrolled **infiltration** of outside air through the building fabric or the use of deliberate **natural ventilation** strategies. Advanced air filtration and treatment processes such as *scrubbing*, can provide ventilation air by cleaning and recirculating a proportion of the air inside a building.

## Types of ventilation

- **Mechanical or forced ventilation:** through an **air handling unit** or direct injection to a space by a fan. A local exhaust fan can enhance infiltration or natural ventilation, thus increasing the ventilation air flow rate.
- **Natural ventilation** occurs when the air in a space is changed with outdoor air without the use of mechanical systems, such as a fan. Most often natural ventilation is assured through operable windows but it can also be achieved through temperature and pressure differences between spaces. Open windows or vents are not a good choice for ventilating a basement or other below ground structure. Allowing outside air into a cooler below ground space will cause problems with humidity and condensation.
- **Mixed Mode Ventilation** or **Hybrid ventilation:** utilises both mechanical and natural ventilation processes. The mechanical and natural components may be used in conjunction with each other or separately at different times of day. The natural component, sometimes subject to unpredictable external weather conditions may not always be adequate to ventilate the desired space. The mechanical component is then used to increase the overall ventilation rate so that the desired internal conditions are met. Alternatively the mechanical component may be used as a control measure to regulate the natural ventilation process, for example, to restrict the air change rate during periods of high wind speeds.
- **Infiltration** is separate from *ventilation*, but is often used to provide *ventilation air*.

## **Ventilation rate**

The **ventilation rate**, for CII buildings, is normally expressed by the volumetric flowrate of outside air being introduced to the building. The typical units used are cubic feet per minute (CFM) or liters per second (L/s). The ventilation rate can also be expressed on a per person or per unit floor area basis, such as CFM/p or CFM/ft<sup>2</sup>, or as *air changes per hour*.

For residential buildings, which mostly rely on infiltration for meeting their ventilation needs, the common ventilation rate measure is the number of times the whole interior volume of air is replaced per hour, and is called **air changes per hour** (*I* or *ACH*; units of 1/h). During the winter, ACH may range from 0.50 to 0.41 in a tightly insulated house to 1.11 to 1.47 in a loosely insulated house.

ASHRAE now recommends ventilation rates dependent upon floor area, as a revision to the 62-2001 standard whereas the minimum ACH was 0.35, but no less than 15 CFM/person (7.1 L/s/person). As of 2003, the standards have changed to an addition of 3 CFM/100 sq. ft. (15 l/s/100 sq. m.) to the 7.5 CFM/person (3.5 L/s/person) standard.

## **Ventilation standards**

- In 1973, in response to the 1973 oil crisis and conservation concerns, ASHRAE Standards 62-73 and 62-81 reduced required ventilation from 10 CFM (4.76 L/S) per person to 5 CFM (2.37 L/S) per person. This was found to be a primary cause of sick building syndrome.
- Current ASHRAE standards (Standard 62-89) states that appropriate ventilation guidelines are 20 CFM (9.2 L/s) per person in an office building, and 15 CFM (7.1 L/s) per person for schools. In commercial environments with tobacco smoke, the ventilation rate may range from 25 CFM to 125 CFM.

In certain applications, such as submarines, pressurized aircraft, and spacecraft, ventilation air is also needed to provide oxygen, and to dilute carbon dioxide for survival. Batteries in submarines also discharge hydrogen gas, which must also be ventilated for health and safety. In any pressurized, regulated environment, ventilation is necessary to control any fires that may occur, as the flames may be deprived of oxygen.

ANSI/ASHRAE (Standard 62-89) sets maximum CO<sub>2</sub> guidelines in commercial buildings at 1000 ppm, however, OSHA has set a limit of 5000 ppm over 8 hours.

Ventilation guidelines are based upon the minimum ventilation rate required to maintain acceptable levels of bioeffluents. Carbon dioxide is used as a reference point, as it is the gas of highest emission at a relatively constant value of 0.005 L/s. The mass balance equation is:

$$Q = G/(C_i - C_a)$$

- $Q$  = ventilation rate (L/s)
- $G$  = CO<sub>2</sub> generation rate
- $C_i$  = acceptable indoor CO<sub>2</sub> concentration
- $C_a$  = ambient CO<sub>2</sub> concentration

### ***Ventilation equipment***

- Fume hood
- Biological safety cabinet
- Dilution ventilation
- Room air distribution
- Heat recovery ventilation

### ***Natural ventilation***

Natural ventilation involves harnessing naturally available forces to supply and removing air through an enclosed space. There are three types of natural ventilation occurring in buildings: wind driven ventilation, pressure-driven flows, and stack ventilation. The pressures generated by 'the stack effect' rely upon the buoyancy of heated or rising air. Wind driven ventilation relies upon the force of the prevailing wind to pull and push air through the enclosed space as well as through breaches in the building's envelope. Natural ventilation is generally impractical for larger buildings, as they tend to be large, sealed and climate controlled specifically by HVAC systems. Both are examples of passive engineering and have applications in renewable energy.

### ***Demand-controlled ventilation (DCV)***

DCV makes it possible to maintain proper ventilation and improve air quality while saving energy. ASHRAE has determined that: "It is consistent with the Ventilation rate procedure that Demand Control be permitted for use to reduce the total outdoor air supply during periods of less occupancy." CO<sub>2</sub> sensors will control the amount of ventilation for the actual number of occupants. During design occupancy, a unit with the DCV system will deliver the same amount of outdoor air as a unit using the ventilation-rate procedure. However, DCV can generate substantial energy savings whenever the space is occupied below the design level.

### ***Local exhaust ventilation***

Local exhaust ventilation addresses the issue of avoiding the contamination of indoor air by specific high-emission sources by capturing airborne contaminants before they are spread into the environment. This can include water vapor control, lavatory bioeffluent control, solvent vapors from industrial processes, and dust from wood- and metal-working machinery. Air can be exhausted through pressurized hoods or through the use of fans and pressurizing a specific area.

A local exhaust system is composed of 5 basic parts

1. A hood that captures the contaminant at its source
2. Ducts for transporting the air
3. An air-cleaning device that removes/minimizes the contaminant
4. A fan that moves the air through the system
5. An exhaust stack through which the contaminated air is discharged

## ***Ventilation and combustion***

Combustion (e.g., fireplace, gas heater, candle, oil lamp, etc.) consumes oxygen while producing carbon dioxide and other unhealthy gases and smoke, requiring ventilation air. An open chimney promotes infiltration (i.e. natural ventilation) because of the negative pressure change induced by the buoyant, warmer air leaving through the chimney. The warm air is typically replaced by heavier, cold air.

Ventilation in a structure is also needed for removing water vapor produced by respiration, burning, and cooking, and for removing odors. If water vapor is permitted to accumulate, it may damage the structure, insulation, or finishes. When operating, an air conditioner usually removes excess moisture from the air. A dehumidifier may also be appropriate for removing airborne moisture.

## ***Smoking and ventilation***

ASHRAE standard 62 states that air removed from an area with **environmental tobacco smoke** shall not be recirculated into ETS-free air. A space with ETS requires more ventilation to achieve similar perceived air quality to that of a non-smoking environment.

The amount of ventilation in an ETS area is equal to the amount of ETS-free area plus the amount  $V$ , where:

$$V = DSD \times VA \times A/60E$$

- $V$  = recommended extra flow rate in CFM (L/s)
- DSD = design smoking density (estimated number of cigarettes smoked per hour per unit area)
- VA = volume of ventilation air per cigarette for the room being designed (ft<sup>3</sup>/cig]
- E = contaminant removal effectiveness

## ***Problems***

In hot, humid climates, unconditioned ventilation air will deliver approximately one pound of water each day for each cubic foot per minute of outdoor air per day, annual average. This is a great deal of moisture, and it can create serious indoor moisture and mold problems.

- Ventilation efficiency is determined by design and layout, and is dependent upon placement and proximity of diffusers and return air outlets. If they are located closely together, supply air may mix with stale air, decreasing efficiency of the HVAC system, and creating air quality problems.
- System imbalances occur when components of the HVAC system are improperly adjusted or installed, and can create pressure differences (too much circulating air creating a draft or too little circulating air creating stagnancy).
- Cross-contamination occurs when pressure differences arise, forcing potentially contaminated air from one zone to an uncontaminated zone. This often involves undesired odors or VOCs.
- Re-entry of exhaust air occurs when exhaust outlets and fresh air intakes are either too close, or prevailing winds change exhaust patterns, or by infiltration between intake and exhaust air flows.
- Entrainment of contaminated outside air through intake flows will result in indoor air contamination. There are a variety of contaminated air sources, ranging from industrial effluent to VOCs put off by nearby construction work.

### ***Air Quality Procedures***

Ventilation Rate Procedure is rate based on standard, and “prescribes the rate at which ventilation air must be delivered to a space and various means to condition that air.” Air quality is assessed (through CO<sub>2</sub> measurement) and ventilation rates are mathematically derived using constants.

Indoor Air Quality Procedure “uses one or more guidelines for the specification of acceptable concentrations of certain contaminants in indoor air but does not prescribe ventilation rates or air treatment methods.” This addresses both quantitative and subjective evaluation, and is based on the Ventilation Rate Procedure. It also accounts for potential contaminants that may have no measured limits, or limits are not set (such as formaldehyde offgassing from carpet and furniture).

## Chapter 10

# Air Handler

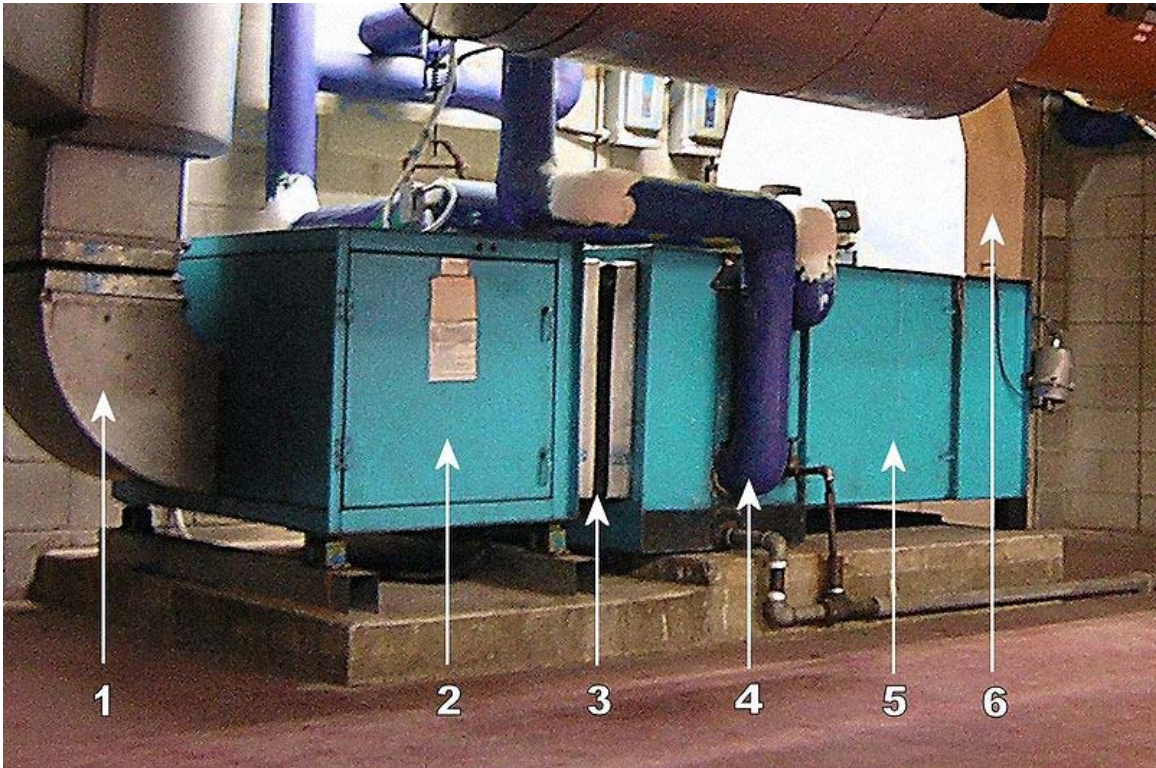

An air handling unit; air flow is from the right to left in this case. Some AHU components shown are:

- 1 - Supply duct
- 2 - Fan compartment
- 3 - Vibration isolator ('flex joint')
- 4 - Heating and/or cooling coil

- 5 - Filter compartment
- 6 - Mixed (recirculated + outside) air duct



A rooftop packaged unit or RTU

An **air handler**, or **air handling unit** (often abbreviated to **AHU**), is a device used to condition and circulate air as part of a heating, ventilating, and air-conditioning (**HVAC**) system. An air handler is usually a large metal box containing a blower, heating or cooling elements, filter racks or chambers, sound attenuators, and dampers. Air handlers usually connect to ductwork that distributes the conditioned air through the building and returns it to the AHU. Sometimes AHUs discharge (*supply*) and admit (*return*) air directly to and from the space served without ductwork.

Small air handlers, for local use, are called **terminal units**, and may only include an air filter, coil, and blower; these simple terminal units are called blower coils or fan coil units. A larger air handler that conditions 100% outside air, and no recirculated air, is known as a **makeup air unit (MAU)**. An air handler designed for outdoor use, typically on roofs, is known as a **packaged unit (PU)** or **rooftop unit (RTU)**.

### ***Air handler components***

#### **Blower/fan**

Air handlers typically employ a large squirrel cage blower driven by an AC induction electric motor to move the air. The blower may operate at a single speed, offer a variety

of set speeds, or be driven by a Variable Frequency Drive to allow a wide range of air flow rates. Flow rate may also be controlled by inlet vanes or outlet dampers on the fan. Some residential air handlers (central 'furnaces' or 'air conditioners') use a brushless DC electric motor that has variable speed capabilities.

Multiple blowers may be present in large commercial air handling units, typically placed at the end of the AHU and the beginning of the supply ductwork (therefore also called "supply fans"). They are often augmented by fans in the return air duct ("return fans") pushing the air into the AHU.

## **Heating and/or cooling elements**

Air handlers may need to provide heating, cooling, or both to change the supply air temperature depending on the location and the application.

Smaller air handlers may contain a fuel-burning heater or a refrigeration evaporator, placed directly in the air stream. Electric resistance and heat pumps can be used as well. Evaporative cooling is possible in dry climates.

Large commercial air handling units contain coils that circulate hot water or steam for heating, and chilled water for cooling. Coils are typically manufactured from copper for the tubes, with copper or aluminium fins to aid heat transfer. Cooling coils will also employ eliminator plates to remove and drain condensate. The hot water or steam is provided by a central boiler, and the chilled water is provided by a central chiller. Downstream temperature sensors are typically used to monitor and control 'off coil' temperatures, in conjunction with an appropriate motorized control valve prior to the coil.

## **Filters**

Air filtration is almost always present in order to provide clean dust-free air to the building occupants. It may be via simple low-MERV pleated media, HEPA, electrostatic, or a combination of techniques. Gas-phase and ultraviolet air treatments may be employed as well.

It is typically placed first in the AHU in order to keep all its components clean. Depending upon the grade of filtration required, typically filters will be arranged in two (or more) banks with a coarse-grade panel filter provided in front of a fine-grade bag filter, or other 'final' filtration medium. The panel filter is cheaper to replace and maintain, and thus protects the more expensive bag filters.

The life of a filter may be assessed by monitoring the pressure drop through the filter medium at design air volume flow rate. This may be done by means of a visual display, using a pressure gauge, or by a pressure switch linked to an alarm point on the building control system. Failure to replace a filter may eventually lead to its collapse, as the forces exerted upon it by the fan overcome its inherent strength, resulting in collapse and thus contamination of the air handler and downstream ductwork.

## Humidifier

Humidification is often necessary in colder climates where continuous heating will make the air drier, resulting in uncomfortable air quality and increased static electricity.

Various types of humidification may be used:

- **Evaporative:** dry air blown over a reservoir will evaporate some of the water. The rate of evaporation can be increased by spraying the water onto baffles in the air stream.
- **Vaporizer:** steam or vapour from a boiler is blown directly into the air stream.
- **Spray mist:** water is diffused either by a nozzle or other mechanical means into fine droplets and carried by the air.
- **Ultrasonic:** A tray of fresh water in the airstream is excited by an ultrasonic device forming a fog or water mist.
- **Wetted medium:** A fine fibrous medium in the airstream is kept moist with fresh water from a header pipe with a series of small outlets. As the air passes through the medium it entrains the water in fine droplets. This type of humidifier can quickly clog if the primary air filtration is not maintained in good order.

## Mixing chamber

In order to maintain indoor air quality, air handlers commonly have provisions to allow the introduction of outside air into, and the exhausting of air from the building. In temperate climates, mixing the right amount of cooler outside air with warmer return air can be used to approach the desired supply air temperature. A mixing chamber is therefore used which has dampers controlling the ratio between the return, outside, and exhaust air.

## Heat recovery device

A heat recovery device heat exchanger of many types, may be fitted to the air handler between supply and extract airstreams for energy savings and increasing capacity. These types more commonly include for:

- **Recuperator, or Plate Heat exchanger:** A sandwich of plastic or metal plates with interlaced air paths. Heat is transferred between airstreams from one side of the plate to the other. The plates are typically spaced at 4 to 6mm apart. Can also be used to recover coolth. Heat recovery efficiency up to 70%.
- **Thermal Wheel, or Rotary heat exchanger:** A slowly rotating matrix of finely corrugated metal, operating in both opposing airstreams. When the air handling unit is in heating mode, heat is absorbed as air passes through the matrix in the exhaust airstream, during one half rotation, and released during the second half rotation into the supply airstream in a continuous process. When the air handling unit is in cooling mode, heat is released as air passes through the matrix in the exhaust airstream, during one half rotation, and absorbed during the second half rotation into the supply airstream. Heat recovery efficiency up to 85%. Wheels are

- also available with a hygroscopic coating to provide latent heat transfer and also the drying or humidification of airstreams
- Run around coil: Two air to liquid heat exchanger coils, in opposing airstreams, piped together with a circulating pump and using water or a brine as the heat transfer medium. This device, although not very efficient, allows heat recovery between remote and sometimes multiple supply and exhaust airstreams. Heat recovery efficiency up to 50%.
  - Heat Pipe: Operating in both opposing air paths, using a confined refrigerant as a heat transfer medium. The 'pipe' is multiple sealed pipes mounted in a coil configuration with fins to increase heat transfer. Heat is absorbed on one side of the pipe, by evaporation of the refrigerant, and released at the other side, by condensation of the refrigerant. Condensed refrigerant flows by gravity to the first side of the pipe to repeat the process. Heat recovery efficiency up to 65%.

## **Controls**

Controls are necessary to regulate every aspect of an air handler, such as: flow rate of air, supply air temperature, mixed air temperature, humidity, air quality. They may be as simple as an off/on thermostat or as complex as a building automation system using BACnet or LonWorks, for example.

Common control components include temperature sensors, humidity sensors, sail switches, actuators, motors, and controllers.

## **Vibration isolators**

The blowers in an air handler can create substantial vibration and the large area of the duct system would transmit this noise and vibration to the occupants of the building. To avoid this, vibration isolators (flexible sections) are normally inserted into the duct immediately before and after the air handler and often also between the fan compartment and the rest of the AHU. The rubberized canvas-like material of these sections allow the air handler to vibrate without transmitting much vibration to the attached ducts.

The fan compartment can be further isolated by placing it on a spring suspension, which will mitigate the transfer of vibration through the floor.

## Chapter 11

# HVAC Control System and Duct (HVAC)

## HVAC control system

A **HVAC control system** is a computerized control system for climate control in buildings. Stand alone control devices may be pneumatic or electronic. Some may have microprocessors, but to be considered a "control system", computerized and networked are expected requirements. HVAC stands for *heating, ventilation, air-conditioning*. Often, these integrate fire, security, and lighting controls into one system. These systems typically use one or more central controllers to command and monitor the remote terminal unit controllers, and they communicate with one or more personal computers that are used as the operator interface. These control systems are typically used on large commercial and industrial buildings to allow central control of many HVAC units around the building(s). The latest systems use ethernet for communications between central controllers--allowing remote access from a web browser.

### ***Direct digital control***

Central controllers and most terminal unit controllers are programmable, meaning the direct digital control program code may be customized for the intended use. The program features include time schedules, setpoints, controllers, logic, timers, trend logs, and alarms. The unit controllers typically have analog and digital inputs that allow measurement of the variable (temperature, humidity, or pressure) and analog and digital outputs for control of the transport medium (hot/cold water and/or steam). Digital inputs are typically (dry) contacts from a control device, and analog inputs are typically a voltage or current measurement from a variable (temperature, humidity, velocity, or pressure) sensing device. Digital outputs are typically relay contacts used to start and stop equipment, and analog outputs are typically voltage or current signals to control the movement of the medium (air/water/steam) control devices such as valves, dampers, and motors.

Group of DDC controllers, networked or not, form a layer of system themselves. This "subsystem" is vital to the performance and basic operation of the overall HVAC system. The DDC system is the "brain" of the HVAC system. It dictates the position of every damper and valve in a system. It determines which fans, pumps and chiller run and at what speed or capacity. With this configurable intelligency in this "brain", we are moving to the concept of building automation.

## ***Building Automation System***

More complex HVAC systems can interface to Building Automation System (BAS), to allow the building owners to have more control over the heating or cooling units. The building owner can monitor the system and respond to alarms generated by the system from local or remote locations. The system can be scheduled for occupancy or the configuration can be changed from the BAS. Sometimes the BAS is directly controlling the HVAC components. Depending on the BAS different interfaces can be used.

## ***History***

It was only natural that the first HVAC controllers would be pneumatic, as the engineers probably understood fluid control. Thus mechanical engineers could use their experience with the properties of steam and air to control the flow of heated or cooled air. There are still pneumatic HVAC systems in operation in some buildings, such as schools and offices, which can be a century old.

After the control of air flow and temperature was standardized, the use of electromechanical relays in ladder logic to switch dampers became standardized. Eventually, the relays became electronic switches, as transistors eventually could handle greater current loads. By 1985, pneumatic control could no longer compete with this new technology.

By the year 2000, computerized controllers were common. Today, some of these controllers can even be accessed by web browsers, which need no longer be in the same building as the HVAC equipment. This allows some economies of scale, as single operations center can easily monitor thousands of buildings.

## Duct (HVAC)

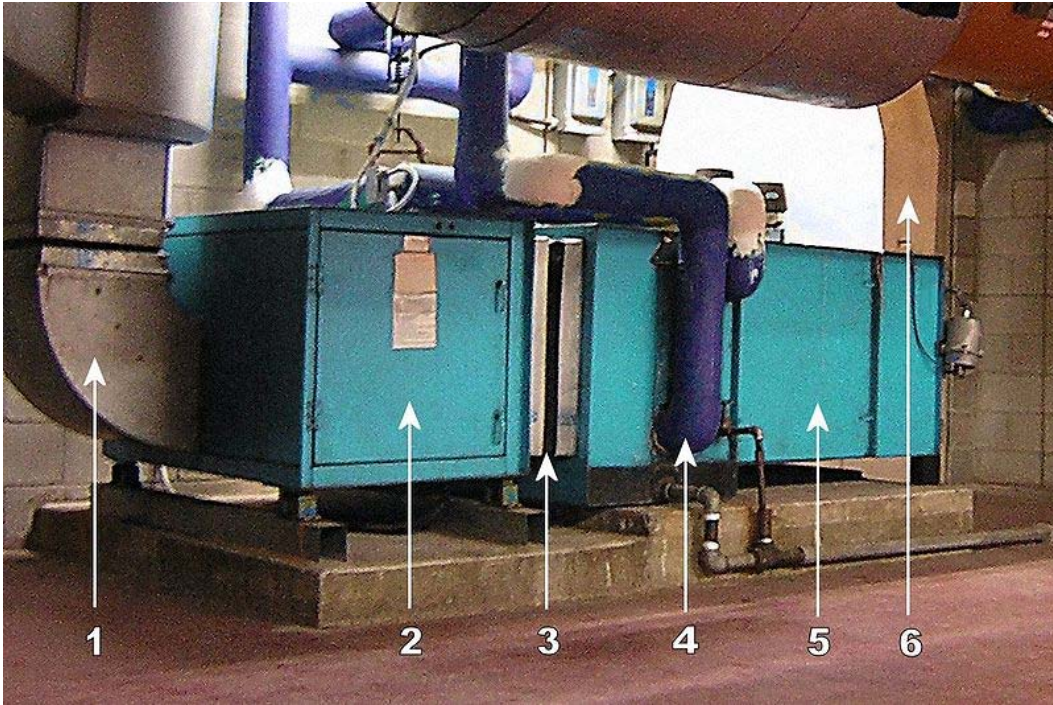

A round galvanized steel duct connecting to a typical diffuser

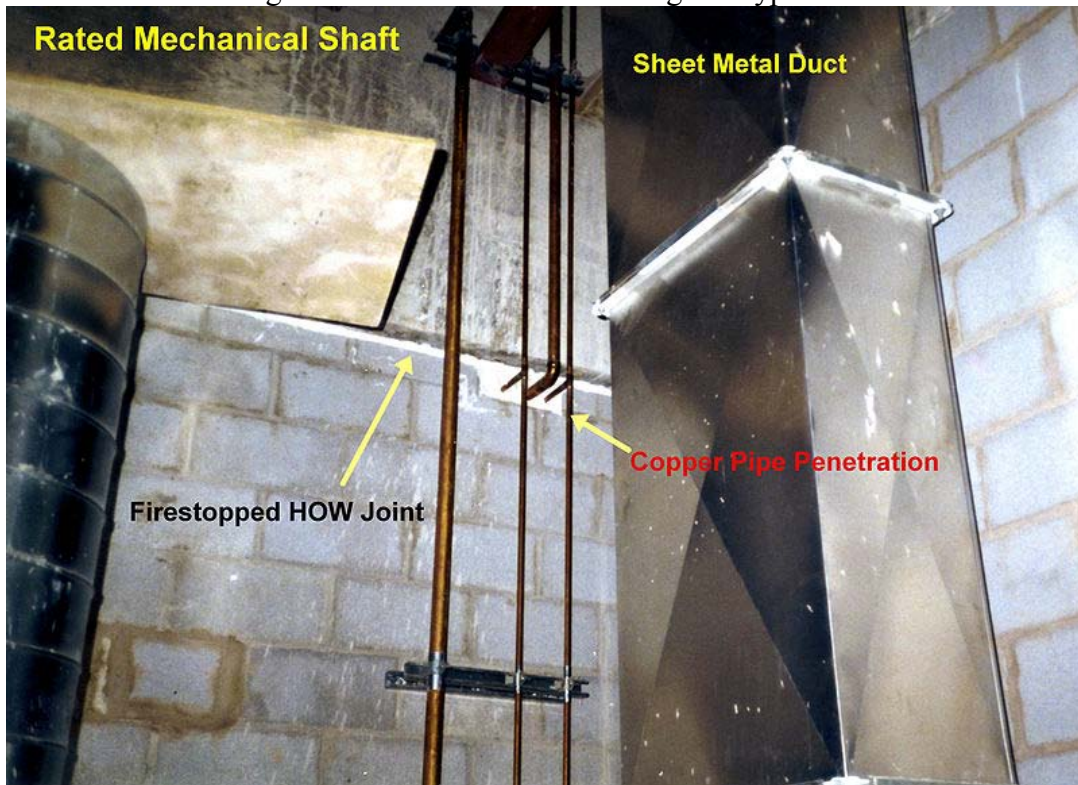

Fire-resistance rated mechanical shaft with HVAC sheet metal ducting and copper piping, as well as "HOW" (Head-Of-Wall) joint between top of concrete block wall and

underside of concrete slab, firestopped with ceramic fibre-based firestop caulking on top of rockwool.

**Ducts** are used in heating, ventilation, and air conditioning (HVAC) to deliver and remove air. These needed airflows include, for example, *supply air*, *return air*, and *exhaust air*. Ducts also deliver, most commonly as part of the supply air, *ventilation air*. As such, air ducts are one method of ensuring acceptable indoor air quality as well as thermal comfort.

A duct system is often called **ductwork**. Planning ('laying out'), sizing, optimizing, detailing, and finding the pressure losses through a duct system is called **duct design**.

## **Materials**

Ducts can be made out of the following materials:

Galvanized mild steel is the standard and most common material used in fabricating ductwork.

## **Polyurethane and Phenolic insulation panels (pre-insulated air ducts)**

Traditionally, air ductwork is made of sheet metal which is installed first and then lagged with insulation as a secondary operation. Ductwork manufactured from rigid insulation panels does not need any further insulation and is installed in a single fix. Light weight and installation speed are among the features of preinsulated aluminium ductwork, also custom or special shapes of ducts can be easily fabricated in the shop or on site.

The ductwork construction starts with the tracing of the duct outline onto the aluminium preinsulated panel, then the parts are typically cut at 45 degree, bent if required to obtain the different fittings (i.e. elbows, tapers) and finally assembled with glue. Aluminium tape is applied to all seams where the external surface of the aluminium foil has been cut. A variety of flanges are available to suit various installation requirements. All internal joints are sealed with sealant.

Among the various types of rigid polyurethane foam panels available, a new water formulated panel stands out. In this particular panel, the foaming process is obtained through the use of water instead of the CFC, HCFC, HFC and HC gasses. And most manufacturers of rigid polyurethane foam panels use normal pentane as foaming agent instead of the CFC, HCFC, HFC and HC gasses, so do manufacturers of rigid phenolic foam panels.

A rigid phenolic insulation ductwork system is available and complies with the UL 181 standard for class 1 air ductwork.

Both polyurethane foam panels and phenolic foam panels are then coated with aluminum sheets on both sides, with outside aluminum thicknesses that can vary from 80

micrometres for indoor use to 200 micrometres for external use or high air pressure in order to guarantee the high mechanical characteristics of the duct, or then coated with aluminum sheets on inside, and coated with 200 micrometres sheet metal or pre-painted sheet metal on outside.

### **Fiberglass duct board (preinsulated non metallic ductwork)**

Fiberglass duct board panels provide built-in thermal insulation and the interior surface absorbs sound, helping to provide quiet operation of the HVAC system. The duct board is formed by sliding a specially-designed knife along the board using a straightedge as a guide; the knife automatically trims out a "valley" with 45° sides; the valley does not quite penetrate the entire depth of the duct board, providing a thin section that acts as a hinge. The duct board can then be folded along the valleys to produce 90° folds, making the rectangular duct shape in the fabricator's desired size. The duct is then closed with staples and special aluminum or similar 'metal-backed' tape. Commonly available duct tape should not be used on air ducts, metal, fiberglass, or otherwise, that are intended for long-term use; the adhesive on so called 'duct tape' dries and releases with time.

### **Flexible Ducting**

Flexible ducts, known as *flex*, have a variety of configurations, but for HVAC applications, they are typically flexible plastic over a metal wire coil to make round, flexible duct. In the United States, the insulation is usually glass wool, but other markets such as Australia, use both polyester fibre and glass wool for thermal insulation. A protective layer surrounds the insulation, and is usually composed of polyethylene or metalised PET. Flexible duct is very convenient for attaching supply air outlets to the rigid ductwork. However, the pressure loss through flex is higher than for most other types of ducts. As such, designers and installers attempt to keep their installed lengths (*runs*) short, e.g., less than 15 feet or so, and to minimize turns. Kinks in flex must be avoided. Some flexible duct markets prefer to avoid using flexible duct on the return air portions of HVAC systems, however flexible duct can tolerate moderate *negative pressures* - the UL181 test requires a negative pressure of 200 Pa. xax

### **Fabric**

Fabric ducting, also known as air socks, duct socks or textile ducts, are designed for even air distribution throughout the entire length. Usually made of special polyester material, fabric ducts can provide air to a space more effectively than a conventional exposed duct system.

Fabric duct is a misnomer as "fabric duct" is actually an "air distribution device" and is not intended as a conduit (duct) for conditioned air. However, as it often replaces hard or metal ductwork it is easy to perceive it simply as duct. Fabric air dispersion systems, is the more definitive name. As they may be manufactured with venting or orifices for even air distribution along any length of the system, they commonly will provide a more even distribution and blending of the conditioned air in a given space. As "fabric duct" is used

for air distribution, textile ducts are not rated for nor should they be used in ceilings or concealed attic spaces. Applications for fabric duct in raise floor applications; however, are available. Depending on the manufacturer, "fabric duct" is available in standard and custom colours with options for silk screening or other forms of appliques.

"Fabric duct", depending on the manufacturer, may be available in air permeable(porous) or non-porous fabric. As a benchmark, a designer may make the determination of which fabric is more applicable by asking the question if the application would require insulated metal duct? If metal duct would be insulated in a given application or installation, air permeable fabric would be recommended as it will not commonly create condensation on its surface and can therefore be used where air is to be supplied below the dew point. Again; depending on the material and manufacturer, material that eliminates moisture may also be healthier and may also be provided with an active anti-microbial agent to inhibit bacteria growth. Porous material also tends to require less maintenance as it repels dust and other airborne contaminants.

### ***Duct system components***

Besides the ducts themselves, complete ducting systems contain many other components.

### **Vibration isolators**

A duct system often begins at an air handler. The blowers in the air handlers can create substantial vibration and the large area of the duct system would transmit this noise and vibration to the inhabitants of the building. To avoid this, *vibration isolators* (flexible sections) are normally inserted into the duct immediately before and after the air handler. The rubberized canvas-like material of these sections allow the air handler to vibrate without transmitting much vibration to the attached ducts.

### **Take-offs**

Downstream of the air handler, the supply air **trunk duct** will commonly fork, providing air to many individual air outlets such as diffusers, grilles, and registers. When the system is designed with a main duct branching into many subsidiary **branch ducts**, fittings called *take-offs* allow a small portion of the flow in the main duct to be diverted into each branch duct. Take-offs may be fitted into round or rectangular openings cut into the wall of the main duct. The take-off commonly has many small metal tabs that are then bent to retain the take-off on the main duct; round versions are called *spin-in fittings*. Other take-off designs use a snap-in attachment method, sometimes coupled with an adhesive foam gasket to provide improved sealing. The outlet of the take-off then connects to the rectangular, oval, or round branch duct.

### **Stacks, boots, and heads**

Ducts, especially in homes, must often allow air to travel vertically within relatively thin walls. These vertical ducts are called *stacks* and are formed with either very wide and

relatively thin rectangular sections or oval sections. At the bottom of the stack, a *stack boot* provides a transition from an ordinary large round or rectangular duct to the thin wall-mounted duct. At the top, a *stack head* can provide a transition back to ordinary ducting while a *register head* allows the transition to a wall-mounted air register.

## **Volume Control Dampers**

Ducting systems must often provide a method of adjusting the volume of air flow to various parts of the system. VCDs (Volume Control Dampers - Not To Be confused with Smoke/Fire Dampers) provide this function. Besides the regulation provided at the registers or diffusers that spread air into individual rooms, dampers can be fitted within the ducts themselves. These dampers may be manual or automatic. Zone dampers provide automatic control in simple systems while VAVs allow control in sophisticated systems.

## **Smoke/Fire Dampers**

Smoke and Fire dampers are found in ductwork, where the duct passes through a firewall or firecurtain. Smoke dampers are automated with the use of a mechanical motor often referred to as an Actuator. A probe connected to the motor is installed in the run of duct, and detects smoke within the duct system which has been extracted from a room, or which is being supplied from the AHU (Air Handling Unit) or elsewhere within the run. Once smoke is detected within the duct, the Actuator triggers the motor release and the smoke damper will automatically close until manually re-opened.

You will also find Fire dampers in the same places as smoke dampers, depending on the application of the area after the firewall. Unlike smoke dampers, they are not triggered by any electrical system, which is perfect in the event of an electrical failure where the Smoke dampers would fail to close. A fire damper is held open by a bar crossing the corrugated screen, which will break and allow the damper to close when air in the duct is above a certain temperature. This again will then have to be manually re-opened.

## **Plenums**

Plenums are the central distribution and collection units for an HVAC system. The return plenum carries the air from several large return grills (vents) to a central air handler. The supply plenum directs air from the central unit to the rooms which the system is designed to heat or cool.

## **Terminal units**

While single-zone constant air volume systems typically don't have them, other types of air distribution systems often have **terminal units** in the branch ducts. Usually there is one terminal unit per thermal zone. Some types of terminal units are VAV 'boxes' of either single or dual duct, fan-powered mixing boxes of either parallel or series arrangement, and induction terminal units. Terminal units may also include either, or both, a heating or cooling coil.

## **Air terminals**

'Air terminals' are the supply air outlets and 'return' or 'exhaust air inlets'. For supply, diffusers are most common, but grilles, and for very small HVAC systems such as in residences, 'registers' are also used widely. Return or 'exhaust grilles' are used primarily for appearance reasons, but some also incorporate an air filter and are known as 'filter returns'.

## ***Duct cleaning***

The position of the U.S. Environmental Protection Agency (EPA) is that "If no one in your household suffers from allergies or unexplained symptoms or illnesses and if, after a visual inspection of the inside of the ducts, you see no indication that your air ducts are contaminated with large deposits of dust or mold (no musty odor or visible mold growth), having your air ducts cleaned is probably unnecessary."

Studies by the EPA and the Canadian Mortgage and Housing Corporation (CMHC) in the 1990s has lead CMHC to conclude that "duct cleaning will not usually change the quality of the air you breathe, nor will it significantly affect airflows or heating costs".

## **Signs and indicators**

- When cleaning, you need to sweep and dust your furniture more than usual.
- After cleaning, there's still left over dust floating around the house that you can see.
- After or during sleep you experience headaches, nasal congestion, or other sinus problems.
- Rooms in your house have little or no air flow coming from the vents.
- You're constantly getting sick or are experience more allergies than usual
- When you turn on the furnace or air conditioner there's musty or stale odor
- You're experiencing signs of sickness: fatigue, headache, sneezing, stuffy or running nose, irritability, nausea, dry or burning sensation in eyes, nose and throat.

## ***Duct sealing***

Duct Sealing is the sealing of leaks in air ducts in order to reduce air leakage, optimize efficiency, and control entry of pollutants into the home or building. Air pressure combined with air duct leakage can lead to a loss of energy in a HVAC system and duct sealing solves issues of energy loss in the system.

Duct tape is not used for sealing ducts. Building codes call for special fire-resistant tapes, often with foil backings and long lasting adhesives.

Signs of leaky or poorly performing air ducts include:

- Utility bills in winter and summer months above average relative to rate fluctuation
- Spaces or rooms that are difficult to heat or cool
- Duct location in an attic, attached garage, leaky floor cavity, crawl space or unheated basement.

# Glossary of HVAC

**HVAC** (Heating, Ventilation, and Air Conditioning) is a major subdiscipline of mechanical engineering. The goal of HVAC design is to balance indoor environmental comfort with other factors such as installation cost, ease of maintenance, and energy efficiency. The discipline of HVAC includes a large number of specialized terms and acronyms, many of which are summarized in this glossary.

## **HVAC terms**

air changes per hour

The number of times per hour that the volume of a specific room or building is supplied or removed from that space by mechanical and natural ventilation.

Abbreviated **ACH**.

air conditioner

An appliance, system, or mechanism designed to dehumidify and extract heat from an area. Usually this term is reserved for smaller self contained units such as a residential system.

air handler or air handling unit

A central unit consisting of a blower, heating and cooling elements, filter racks or chamber, dampers, humidifier, and other central equipment in direct contact with the airflow. This does not include the ductwork through the building. Abbreviated **AH** or **AHU**.

British thermal unit

Any of several units of energy (heat) in the HVAC industry, each slightly more than 1 kJ. One BTU is the energy required to raise one pound of water one degree Fahrenheit, but the many different types of BTU are based on different interpretations of this “definition”. In the United States the power of HVAC systems (the rate of cooling and dehumidifying or heating) is sometimes expressed in BTU/hour instead of watts. Abbreviated **BTU** or **Btu**.

chiller

A device that removes heat from a liquid via a vapor-compression or absorption refrigeration cycle. This cooled liquid flows through pipes in a building and passes through coils in air handlers, fan-coil units, or other systems, cooling and

- usually dehumidifying the air in the building. Chillers are of two types; air-cooled or water-cooled. Air-cooled chillers are usually outside and consist of condenser coils cooled by fan-driven air. Water-cooled chillers are usually inside a building, and heat from these chillers is carried by recirculating water to a heat sink such as an outdoor cooling tower.
- coil**  
Equipment that performs heat transfer to air when mounted inside an air handling unit or ductwork. It is heated or cooled by electrical means or by circulating liquid or steam within it.
- condenser**  
A component in the basic refrigeration cycle that ejects or removes heat from the system. The condenser is the hot side of an air conditioner or heat pump. Condensers are heat exchangers, and can transfer heat to air or to an intermediate fluid (such as water or an aqueous solution of ethylene glycol) to carry heat to a distant sink, such as ground (earth sink), a body of water, or air (as with cooling towers).
- constant air volume**  
A system designed to provide a constant air flow. This term is applied to HVAC systems that have variable supply-air temperature but constant air flow rates. Most residential forced-air systems are small CAV systems with on/off control. Abbreviated **CAV**.
- controller**  
A device that controls the operation of part or all of a system. It may simply turn a device on and off, or it may more subtly modulate the set point of components. Most controllers are automatic but have user input such as temperature set points, e.g. a thermostat. Controls may be analog or digital.
- damper**  
A plate or gate placed in a duct to control air flow by increasing friction in the duct.
- deep lake water cooling**  
The heat is rejected to deep lake regions to cool homes and offices, reducing the energy costs.
- $\Delta T$**   
(Also delta T) a reference to a temperature difference. It is used to describe the difference in temperature of a heating or cooling fluid as it enters and as it leaves a system.
- duct**  
Specialized housing for the air flow.
- evaporator**  
A component in the basic refrigeration cycle that absorbs or adds heat to the system. Evaporators can be used to absorb heat from air or from a liquid. The evaporator is the cold side of an air conditioner or heat pump.
- fan coil unit**  
A small terminal unit that is often composed of only a blower and a heating and/or cooling coil, as is often used in hotels, condominiums, or apartments. Abbreviated **FCU**.

flow

A transfer of fluid volume per unit time.

fresh air intake

An opening through which outside air is drawn into the building. This may be to replace air in the building that has been exhausted by the ventilation system, or to provide fresh air for combustion of fuel. Abbreviated **FAI**.

furnace

A component of an HVAC system that adds heat to air or an intermediate fluid by burning fuel (natural gas, oil, propane, butane, or other flammable substances) in a heat exchanger.

grille

A facing across a duct opening, often rectangular in shape, containing multiple parallel slots through which air may be delivered or withdrawn from a ventilated space. The grille directs the air flow in a particular direction and prevents the passage of large items.

heat load, heat loss, heat gain

Terms for the amount of heating (heat loss) or cooling (heat gain) needed to maintain desired temperatures and humidities in controlled air. Regardless of how well-insulated and sealed a building is, buildings gain heat from sunlight, conduction through the walls, and internal heat sources such as people and electrical equipment. Buildings lose heat through conduction during cold weather. Engineers use a heat load calculations to determine the HVAC needs of the space being cooled or heated.

intermediate fluid

A liquid or gas used to transfer heat between two heat exchangers. An intermediate fluid is used when the hot and cold fluids are too bulky (such as air) or difficult to handle (such as halocarbon refrigerant) to directly transfer the heat.

louver

1. Components made of multiple smaller blades, sometimes adjustable, placed in ducts or duct entries to control the volume of air flow. When used inside of ducts, their function is similar to that of a **damper**, but they can be manufactured to fit larger openings than a single-piece damper.
2. Blades in a rectangular frame placed in doors or walls to permit the movement of air.

makeup air unit

An air handler that conditions 100% outside air. Typically used in industrial or commercial settings, or in "once-through" (blower sections that only blow air one-way into the building), "low flow" (air handling systems that blow air at a low flow rate), or "primary-secondary" (air handling systems that have an air handler or rooftop unit connected to an add-on makeup unit or hood) commercial HVAC systems. Abbreviated **MAU**.

minimum outside air

- The lowest amount of fresh air flow that can be allowed into a recirculating system. This limit is set to ensure that the interior air remains safe and comfortable to breathe.
- outside air damper  
An automatic **louver** or **damper** that controls the fresh air flow into an **air handler** and modulates to the most energy efficient setting.
- packaged terminal air conditioner  
An air conditioner and heater combined into a single, electrically-powered unit, typically installed through a wall and often found in hotels. Abbreviated **PTAC**.
- packaged unit or rooftop unit  
An air-handling unit, defined as either "recirculating" or "once-through" design, made specifically for outdoor installation. They most often include, internally, their own heating and cooling devices. Very common in some regions, particularly in single-story commercial buildings. Abbreviated **RTU**.
- plenum space  
An enclosed space inside a building or other structure, used for airflow. Often refers to the space between a dropped ceiling and the structural ceiling or a raised floor and the hard floor. Distinct from ductwork as a plenum is part of the structure itself. Cable and piping within a plenum must be properly rated for its fire and smoke indices.
- psychrometric  
The study of the behavior of air-water vapor mixtures. Water vapor plays an important role in energy transfer and human comfort in HVAC design.
- smoke damper  
A **damper** or adjustable **louver** designed to augment the ventilation of a space during a fire.
- system  
General term used to refer to the set or a subset of components that perform a specific HVAC function within a building.
- terminal unit  
A small component that contains a heating coil, cooling coil, automatic damper, or some combination of the three. Used to control the temperature of a single room. Abbreviated **TU**.
- thermal zone  
An individual space or group of neighboring indoor spaces that the HVAC designer expects will have similar thermal loads. Building codes may require zoning to save energy in commercial buildings. Zones are defined in the building to reduce the number of HVAC subsystems, and thus initial cost. For example, for perimeter offices, rather than one zone for each office, all offices facing west can be combined into one zone. Small residences typically have only one conditioned thermal zone, plus unconditioned spaces such as garages, attics, and crawlspaces, and basements.
- underfloor air distribution  
A method for providing ventilation and space conditioning by using the air plenum below a raised floor to distribute conditioned air through diffusers directly to the occupied zone. Abbreviated **UFAD**.

variable air volume

An HVAC system that has a stable supply-air temperature, and varies the air flow rate to meet the temperature requirements. Compared to **constant air volume** systems, these systems conserve energy through lower fan speeds during times of lower temperature control demand. Most new commercial buildings have VAV systems. VAVs may be bypass type or pressure dependent. Pressure dependent type VAVs save energy while both types help in maintaining temperature of the zone that it feeds. Abbreviated **VAV**.